

SANMOTION

STEPPING SYSTEMS

STEPPING MOTOR WITH ENCODER

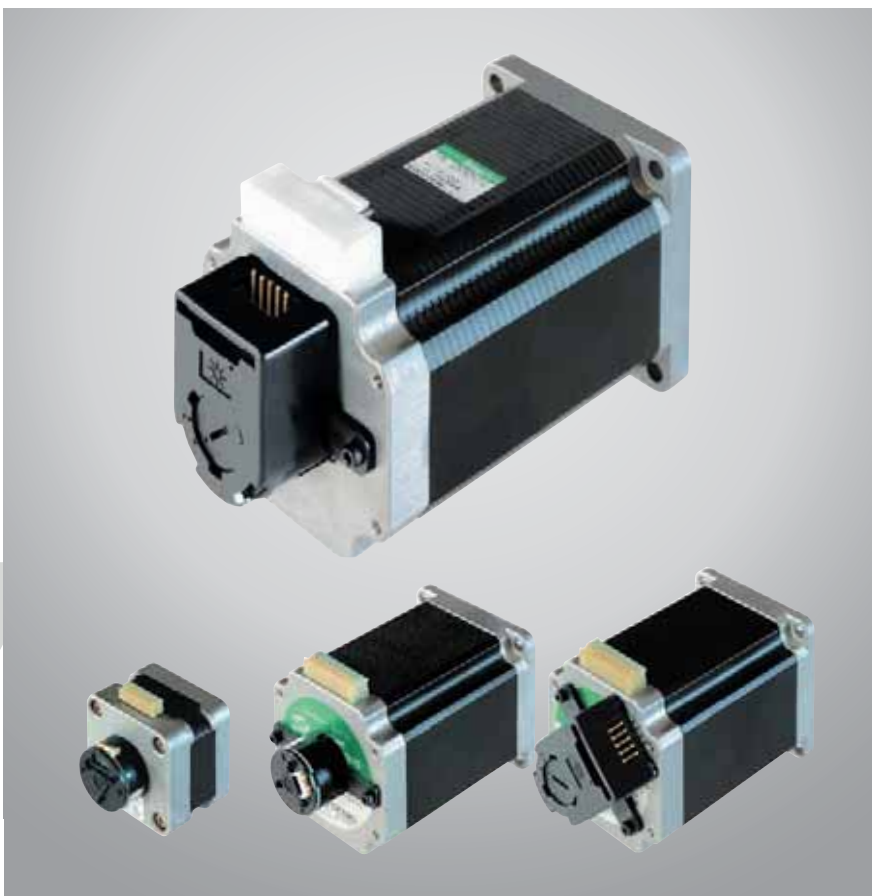

SANYO DENKI

English



STEPPING SYSTEMS

STEPPING MOTOR WITH ENCODER

Content

How to read part numbers	2
References available	2
Stepping Motors	3
Electrical specifications	
Dynamic performances	
General specifications	
Encoder Type S	7
Type L	
Type R	
Dimensions and Connection Diagram	9
Accessories	14

Note : In this catalogue, all references are standard and kept in our stock in Europe. For any special requirement, please contact our sales network.

How to read part numbers

2H 5654 B20 S 2 40

Motor Technology

2H : 2 phase High Torque
 2P : 2 phase 400 steps/rev
 5H : 5 phase High Torque

Motor dimension

5654 =
 Flange 56x56mm Length 54mm

Current per phase

B20 = Bipolar 2.0A U12 = Unipolar 1.2A
 P15 = 1.5A 5 leads (5-phase)

Encoder family

Type S, L or R

2 : 2 channels
 3 : 3 channels

Encoder Resolution

20 : 200 CPR. 40 : 400 CPR.
 50 : 500 CPR.

Options

Ø : standard A→Z : customized products

References available

On above table are introduced available combinations between stepping motors and encoders.

		ENCODER RESOLUTION						
		200 CPR	400 CPR			500 CPR		
		R220	S240	S340	L240	S250	S350	
MOTOR FLANGE SIZE	42mm sq	2H4233B05	✓	○	✓		○	○
		2H4238B17	✓	○	✓		○	○
		2H4241B05		○	✓		○	○
		2H4241U12		○	✓		○	○
		2H4248U12	✓	○	✓		○	○
	56mm sq	2H5654U10	✓	○	✓	✓	○	○
		2H5654U20	○	○	✓	✓	○	○
		2H5654B20	○	○	✓	✓	○	○
		2H5676B20	○	○	✓	✓	○	○
	60mm sq	2H6086U20	○	○	○	○	✓	✓
		2H6086B40	○	○	○	○	✓	✓
		5H6086P15	○	○	○	○	✓	✓

✓ : Set motor + encoder standard.

○ : Set motor + encoder on demand.



Stepping Motors

Hybrid

2-phase and 5-phase motors

Electrical specifications

P/N	Motor Base	Size mm	Step Angle γ	Holding Torque N.m.	Winding type	Current per phase A	Resistance per phase	Inductance mH	Rotor Inertia 10^{-4} kg · m ²	Weight Kg	Encoder resolution CPR
2H4233B05	103H5205	42	1.8	0.26	Bipol	0.48	14	27	0.036	0.23	200, 400
2H4238B17	103H5208	42	1.8	0.39	Bipol	1.7	1.3	3.4	0.056	0.29	200, 400
2H4241B05	103H5209	42	1.8	0.42	Bipol	0.5	18	42	0.062	0.31	400
2H4241U12	103H5209	42	1.8	0.32	Unipol	1.2	3	3.9	0.062	0.31	400
2H4248U12	103H5210	42	1.8	0.37	Unipol	1.2	3.3	3.4	0.074	0.37	200, 400
2H5654U10	103H7123	56	1.8	0.83	Unipol	1	6.7	15	0.21	0.65	200, 400
2H5654U20	103H7123	56	1.8	0.83	Unipol	2	1.6	3.8	0.21	0.65	400
2H5654B20	103H7123	56	1.8	0.83	Bipol	2	0.8	3.8	0.21	0.65	400
2H5676B20	103H7126	56	1.8	1.27	Bipol	2	1.05	4.5	0.36	0.98	400
2H6086U20	103H7823	60	1.8	2.1	Unipol	2	2.7	5.6	0.84	1.34	500
2H6086B40	103H7823	60	1.8	2.7	Bipol	4	0.65	2.4	0.84	1.34	500
5H6086P15	103H7523	60	0.72	1.57	Penta	1.5	1.4	5.4	0.423	1.1	500

Dynamic performances

2H4233B05

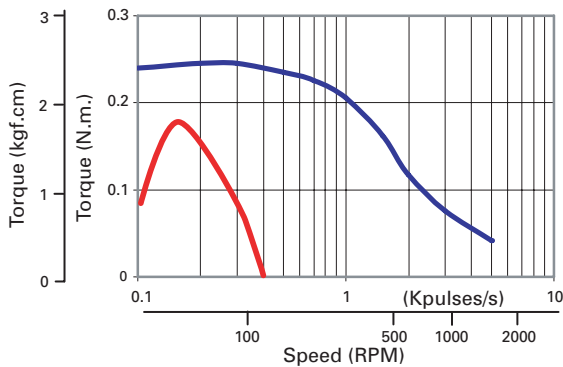

Driver : PMM-BD-4502
 Power voltage : 36VDC
 Current : 0.48A/phase bipolar
 Excitation mode : Full step
 — Pull-out torque [$J_{L2} = 0.94 \times 10^{-4} \text{ kg.m}^2$]
 Using rubber coupling
 — Starting torque [$J_{L1} = 0.8 \times 10^{-4} \text{ kg.m}^2$]

2H4238B17

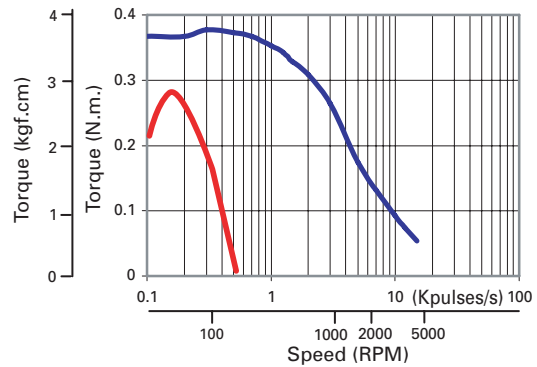

Driver : PMM-BD-4502
 Power voltage : 36VDC
 Current : 1.7A/phase bipolar
 Excitation mode : Full step
 — Pull-out torque [$J_{L2} = 0.94 \times 10^{-4} \text{ kg.m}^2$]
 Using rubber coupling
 — Starting torque [$J_{L1} = 0.8 \times 10^{-4} \text{ kg.m}^2$]

2H4241U12

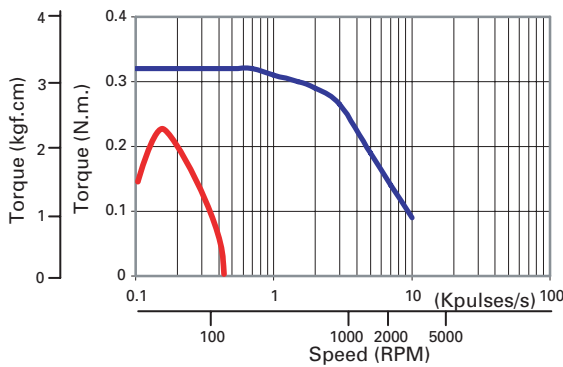

Driver : PMM-MD-23221-21
 Power voltage : 36VDC
 Current : 1.2A/phase unipolar
 Excitation mode : Full step
 — Pull-out torque [$J_{L2} = 0.94 \times 10^{-4} \text{ kg.m}^2$]
 Using rubber coupling
 — Starting torque [$J_{L1} = 0.8 \times 10^{-4} \text{ kg.m}^2$]

2H4241B05

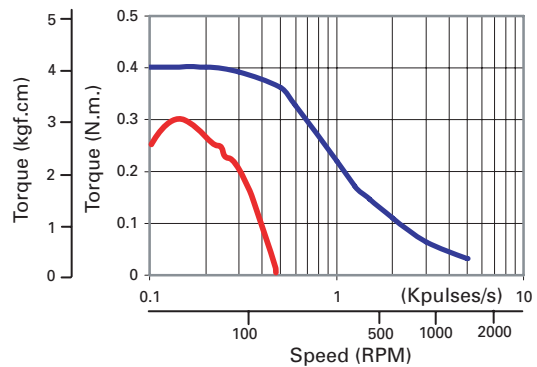

Driver : PMM-BD-4502
 Power voltage : 36VDC
 Current : 0.5A/phase bipolar
 Excitation mode : Full step
 — Pull-out torque [$J_{L2} = 0.94 \times 10^{-4} \text{ kg.m}^2$]
 Using rubber coupling
 — Starting torque [$J_{L1} = 0.21 \times 10^{-4} \text{ kg.m}^2$]

2H4248U12

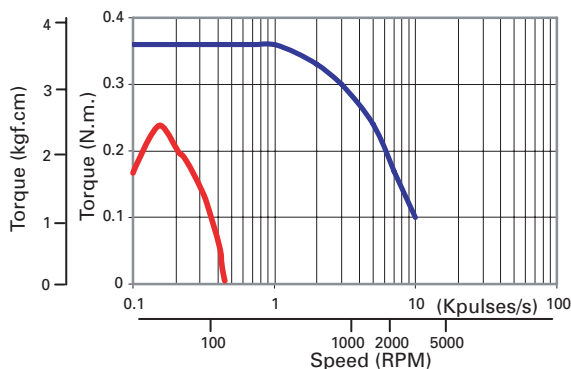

Driver : PMM-MD-23221-21
 Power voltage : 36VDC
 Current : 1.2A/phase
 Excitation mode : Full step
 — Pull-out torque [$J_{L2} = 0.94 \times 10^{-4} \text{ kg.m}^2$]
 Using rubber coupling
 — Starting torque [$J_{L1} = 0.8 \times 10^{-4} \text{ kg.m}^2$]

2H5654U10

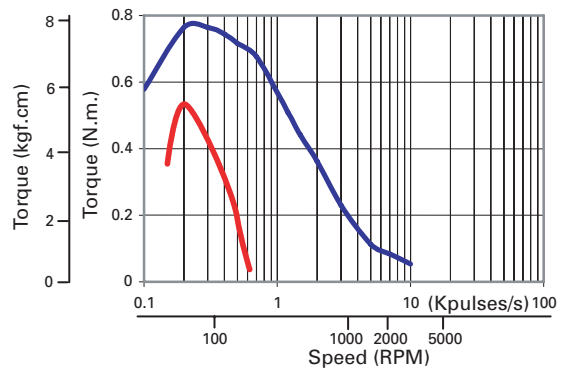

Driver : PMM-MD-23221-10
 Power voltage : 36VDC
 Current : 1.0A/phase unipolar
 Excitation mode : Full step
 — Pull-out torque [$J_{L2} = 0.94 \times 10^{-4} \text{ kg.m}^2$]
 Using rubber coupling
 — Starting torque [$J_{L1} = 0.8 \times 10^{-4} \text{ kg.m}^2$]

Dynamic performances

2H5654U20

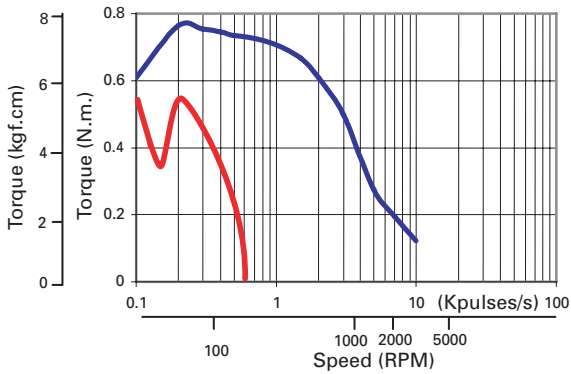

Driver : PMM-MD-23221-10
 Power voltage : 36VDC
 Current : 2.0A/phase unipolar
 Excitation mode : Full step
 — Pull-out torque [$J_{L2} = 0.94 \times 10^{-4} \text{ kg.m}^2$]
 Using rubber coupling
 — Starting torque [$J_{L1} = 0.8 \times 10^{-4} \text{ kg.m}^2$]

2H5654B20

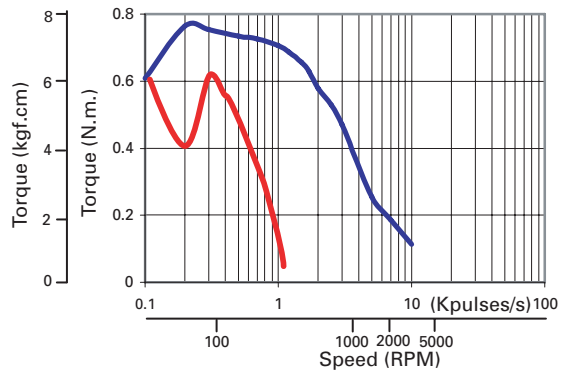

Driver : PMM-BD-4502
 Power voltage : 36VDC
 Current : 2.0A/phase bipolar
 Excitation mode : Full step
 — Pull-out torque [$J_{L2} = 0.94 \times 10^{-4} \text{ kg.m}^2$]
 Using rubber coupling
 — Starting torque [$J_{L1} = 0.21 \times 10^{-4} \text{ kg.m}^2$]

2H5676B20

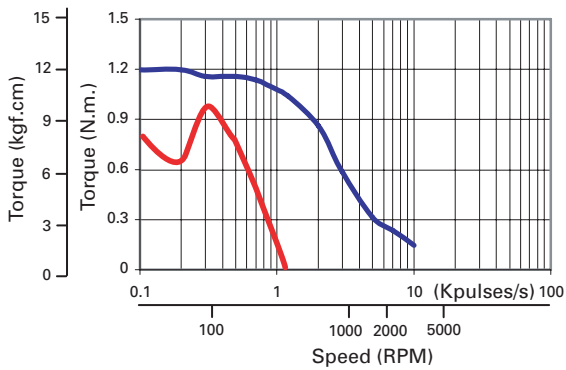

Driver : PMM-BD-4502
 Power voltage : 36VDC
 Current : 2.0A/phase bipolar
 Excitation mode : Full step
 — Pull-out torque [$J_{L2} = 2.6 \times 10^{-4} \text{ kg.m}^2$]
 Using rubber coupling
 — Starting torque [$J_{L1} = 2.6 \times 10^{-4} \text{ kg.m}^2$]

2H6086U20

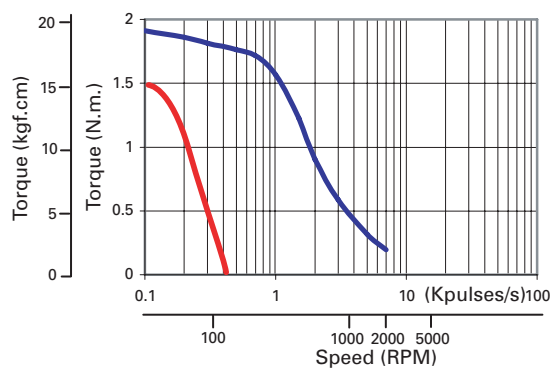

Driver : PMM-MD-23221-10
 Power voltage : 36VDC
 Current : 2.0A/phase unipolar
 Excitation mode : Full step
 — Pull-out torque [$J_{L2} = 7.4 \times 10^{-4} \text{ kg.m}^2$]
 Using rubber coupling
 — Starting torque [$J_{L1} = 7.4 \times 10^{-4} \text{ kg.m}^2$]

2H6086B40

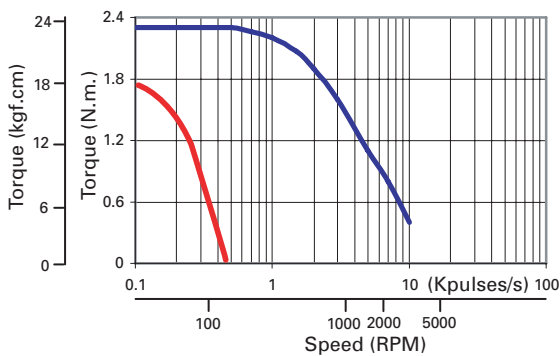

Driver : PMM-BA-4804
 Power voltage : 100VAC
 Current : 4.0A/phase bipolar
 Excitation mode : Full step
 — Pull-out torque [$J_{L2} = 7.4 \times 10^{-4} \text{ kg.m}^2$]
 Using rubber coupling
 — Starting torque [$J_{L1} = 7.4 \times 10^{-4} \text{ kg.m}^2$]

5H6086P15

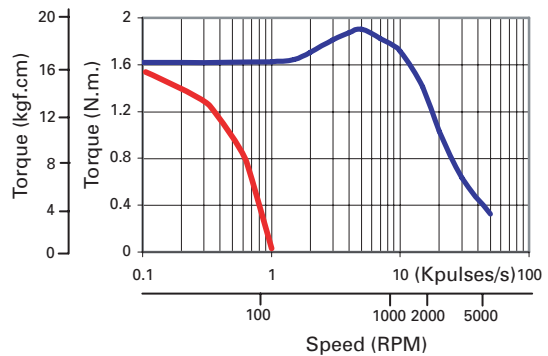

Driver : PMM-BA-5604
 Power voltage : 36VDC
 Current : 1.5A/phase
 Excitation mode :
 — Pull-out torque [$J_{L2} = 7.4 \times 10^{-4} \text{ kg.m}^2$]
 Using rubber coupling
 — Starting torque [$J_{L1} = 7.4 \times 10^{-4} \text{ kg.m}^2$]

General specifications

	2H42	2H56	2H60	5H60
Insulation class	Classe B / 130°C			
Insulation resistance	100M or more when measured with a DC500V megohmmeter between the motor wiring and the frame at normal temperature and humidity			
Withstand voltage	Not influenced when applied 1kVA (0.5kVA for 2H42), 50/60Hz between the motor wound wire and the frame for 1 minute (leak current 1mA) at room temperature and humidity			
Operating environment	Ambient temperature : -10°C to +50°C			
	Ambient humidity : 20 to 90% (no condensation)			
Winding temperature rise	≤ 80 K			
Standing angle error	± 0.09°	± 0.054°		± 0.09°
Axial play	≤ 0.075 mm (load 4.4 N)	≤ 0.75 mm (load 9 N)		
Radial play (1)	≤ 0.025 mm (load 4.4 N)			
Shaft run outs	0.025 mm			
Concentricity of mounting spigot relative to shaft	∅ 0.05 mm	∅ 0.075 mm		
Perpendicularity of mounting surface relative to shaft	0.1 mm	0.075 mm		
Allowable thrust load	10N	15N	20N	15N
Allowable radial load (1)	28N	75N	80N	115N

Note 1 : load point is the position 1/3 from the output shaft end.



Encoder Type S

Optical incremental encoder TTL compatible

Operating Voltage : 4.5 to 5.5 VDC

Counts per Revolution : 400, 500

Max. Reply Frequency : 100 kHz

Diagram

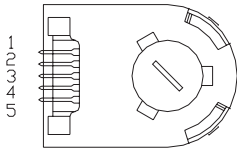

Waveforms

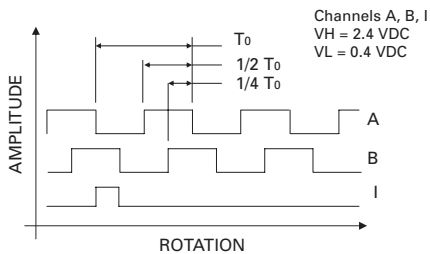

Connection

	2 Channel Encoder	3 Channel Encoder
Pin 1	GND	
Pin 2	NC	Channel I
Pin 3	Channel A	
Pin 4	5 VDC	
Pin 5	Channel B	

Suitable connector
 Molex 2695-05, 2759
 AMP 103686-4, 640442-5
 BERG 65039-032, 4825X-000

Standard P/N

- ✓ S240 : 2 channels, 400 CPR
- ✓ S340 : 3 channels, 400 CPR
- ✓ S250 : 2 channels, 500 CPR
- ✓ S350 : 3 channels, 500 CPR

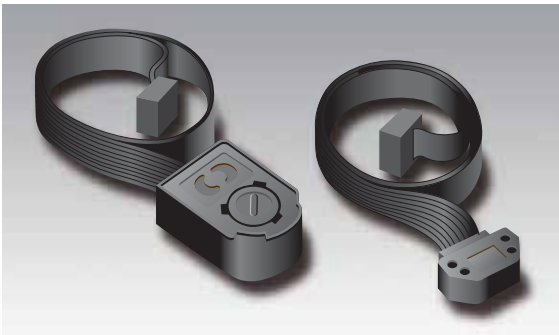

Encoder Type L

Optical incremental encoder Line Driver

Operating Voltage : 4.5 to 5.5VDC

Counts per Revolution : 400

Max. Reply Frequency : 100 kHz

Diagram

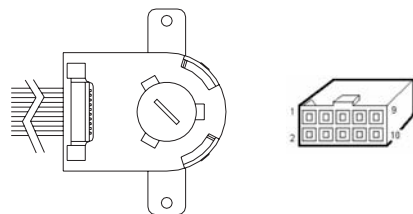

Connection

Pin 1	NC	Pin 6	A
Pin 2	+5 VDC	Pin 7	/B
Pin 3	GND	Pin 8	B
Pin 4	NC	Pin 9	NC
Pin 5	/A	Pin 10	NC

Leadwire output : 480mm - AWG28
 Fitted with connector BERG HE10

Waveforms

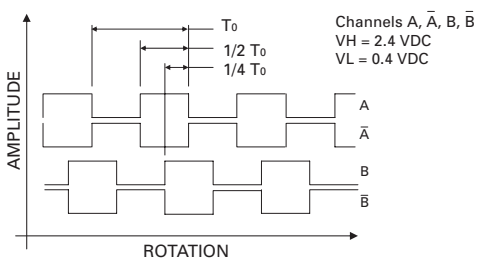

Standard P/N

- ✓ L240 : 2 channels, 400 CPR



Encoder Type R

Optical incremental encoder
 Operating Voltage : 4.5 to 5.5 VDC
 Counts per Revolution : 200
 Max. Reply Frequency : 16 kHz

Diagram

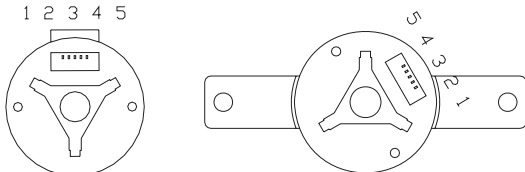

Radial Output for 42mm flange motor

Axial Output for 56mm flange motor

Connection

Pin 1	GND
Pin 2	NC
Pin 3	Channel A
Pin 4	5 VDC
Pin 5	Channel B

Suitable connector Molex 51021-0500

Waveforms

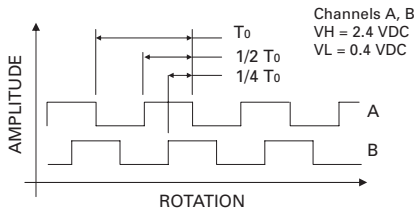

Standard P/N

✓ R220 : 2 channels, 200 CPR

Dimensions and Connection Diagram

	R220	S240	S340	L240	S250	S350
2H4233B05	A1	A2	A2			
2H4238B17	A1	A2	A2			
2H4241B05		A2	A2			
2H4241U12		A3	A3			
2H4248U12	A4	A3	A3			
2H5654U10	B1	B2	B2	B3		
2H5654U20		B2	B2	B3		
2H5654B20		B4	B4	B5		
2H5676B20		B4	B4	B5		
2H6086U20					C1	C1
2H6086B40					C2	C2
5H6086P15					D1	D1

DIAGRAM A1

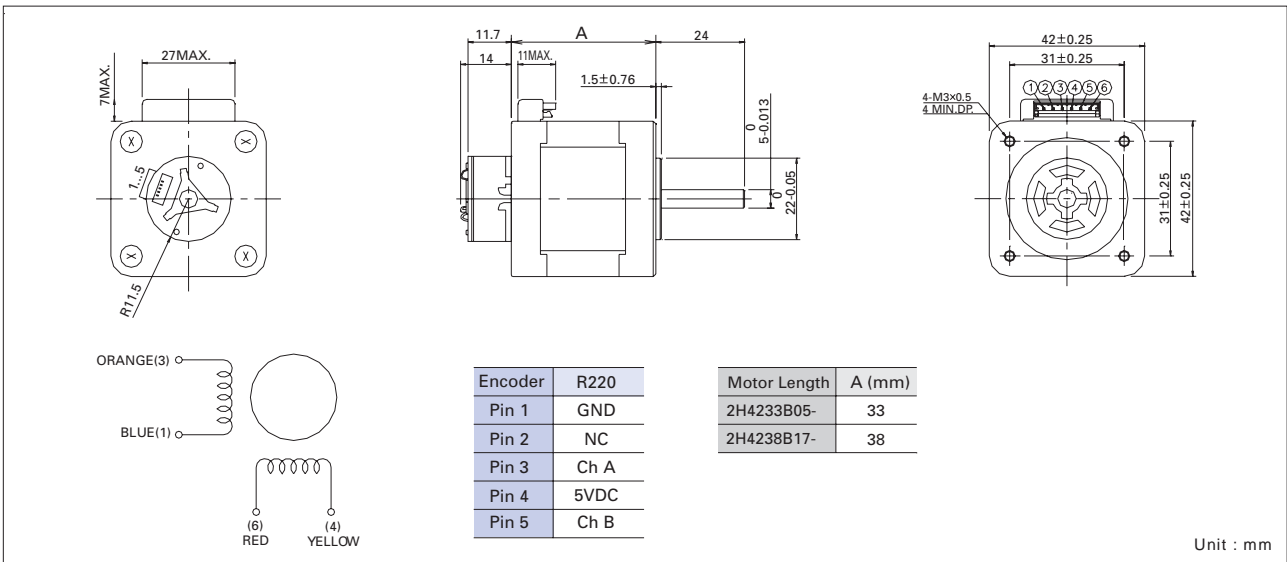

DIAGRAM A2

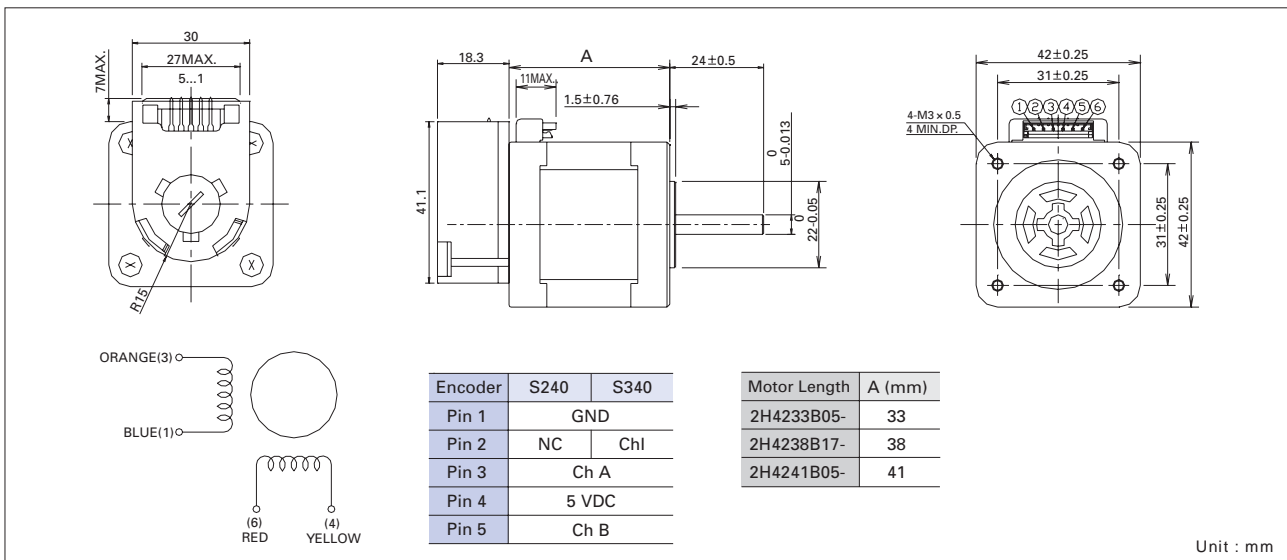

DIAGRAM A3

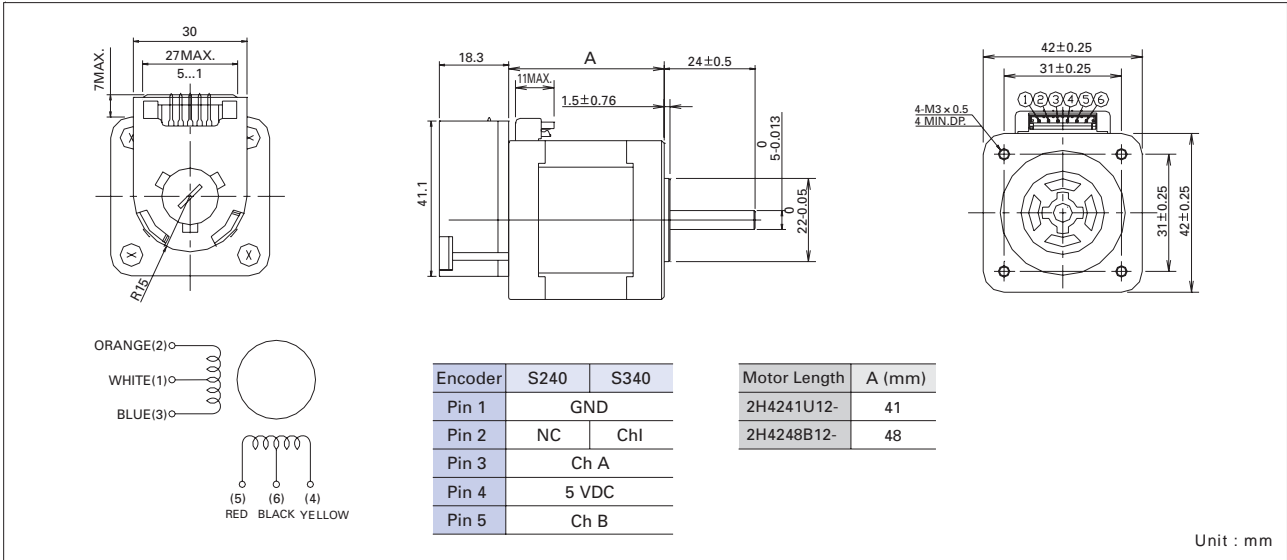
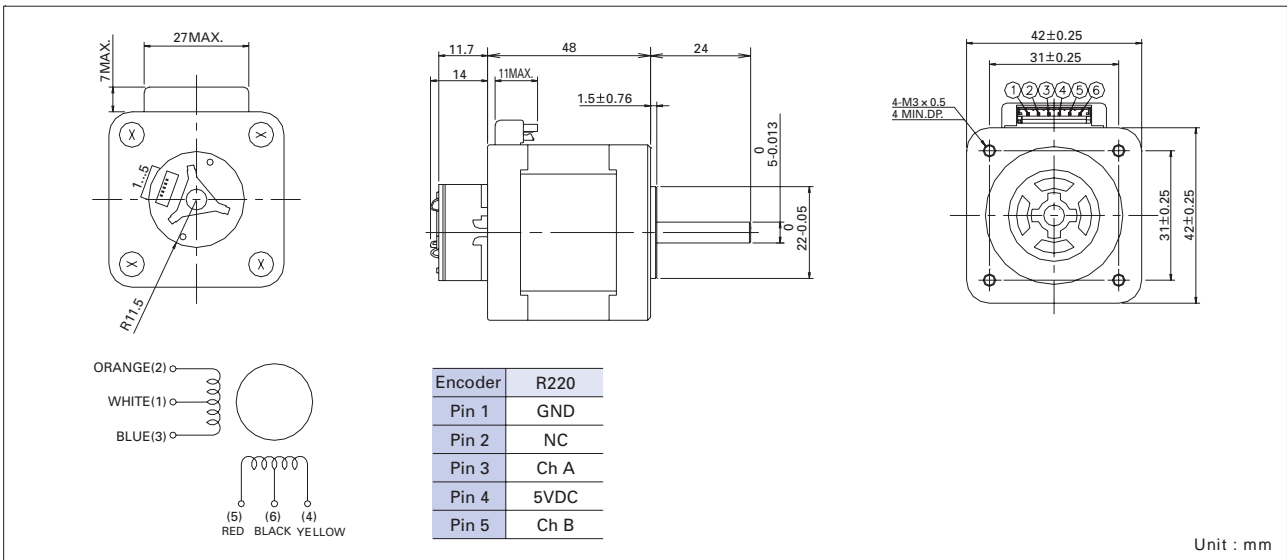

DIAGRAM A4 – MOTOR 2H4248U12



Dimensions and Connection Diagram

DIAGRAM B1 – MOTOR 2H5654U10

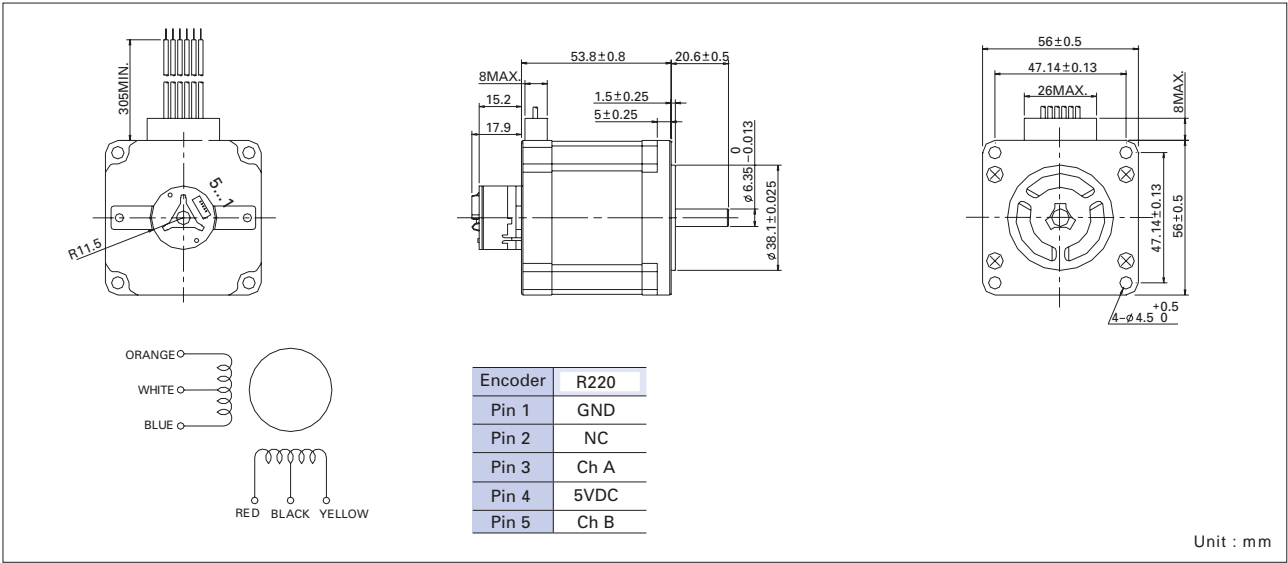

DIAGRAM B2 – MOTOR 2H5654U10 – 2H5654U20

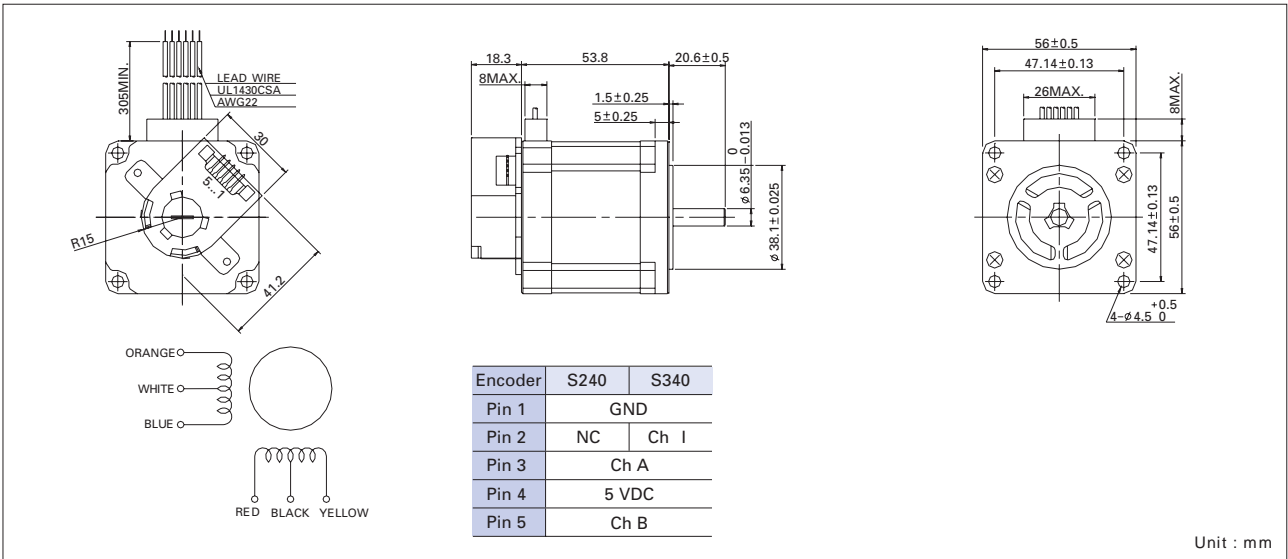

DIAGRAM B3 – MOTOR 2H5654U10 – 2H5654U20

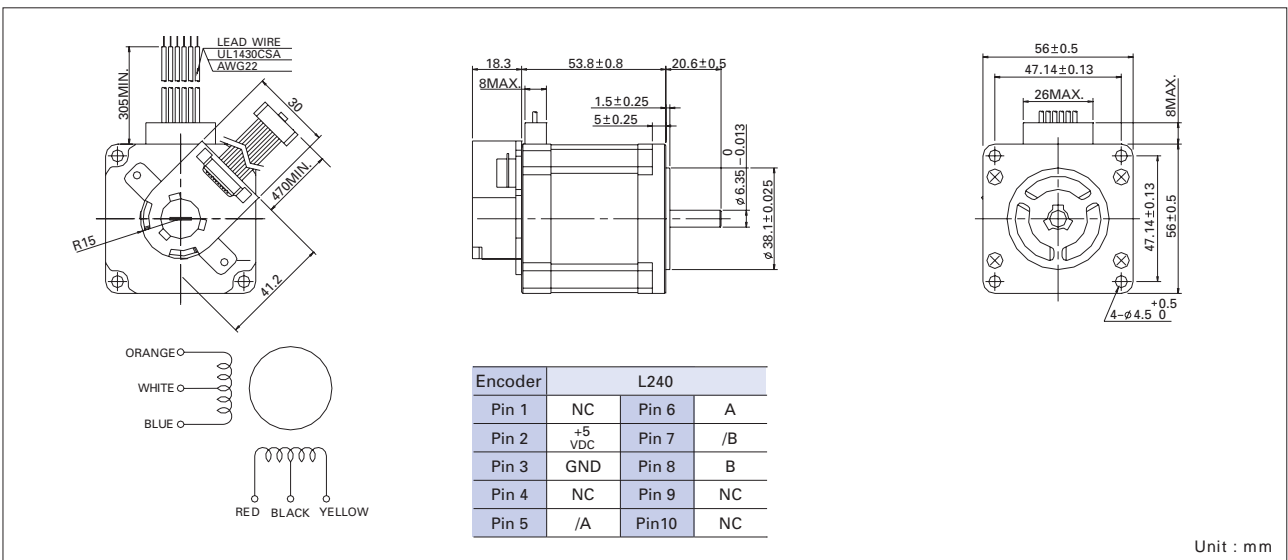

DIAGRAM B4

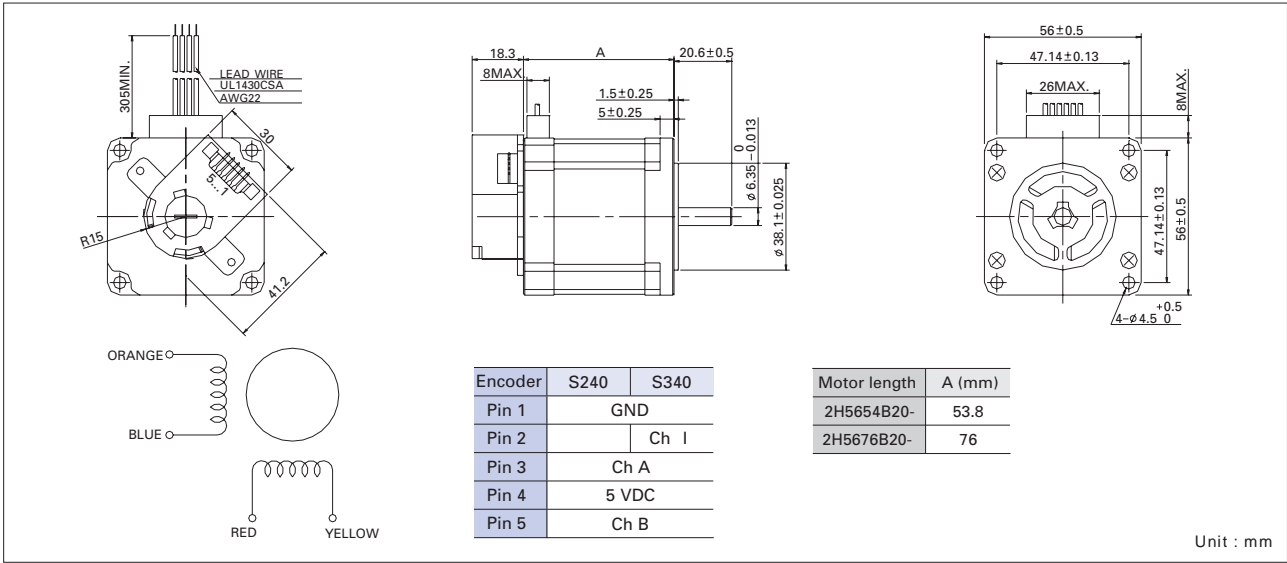
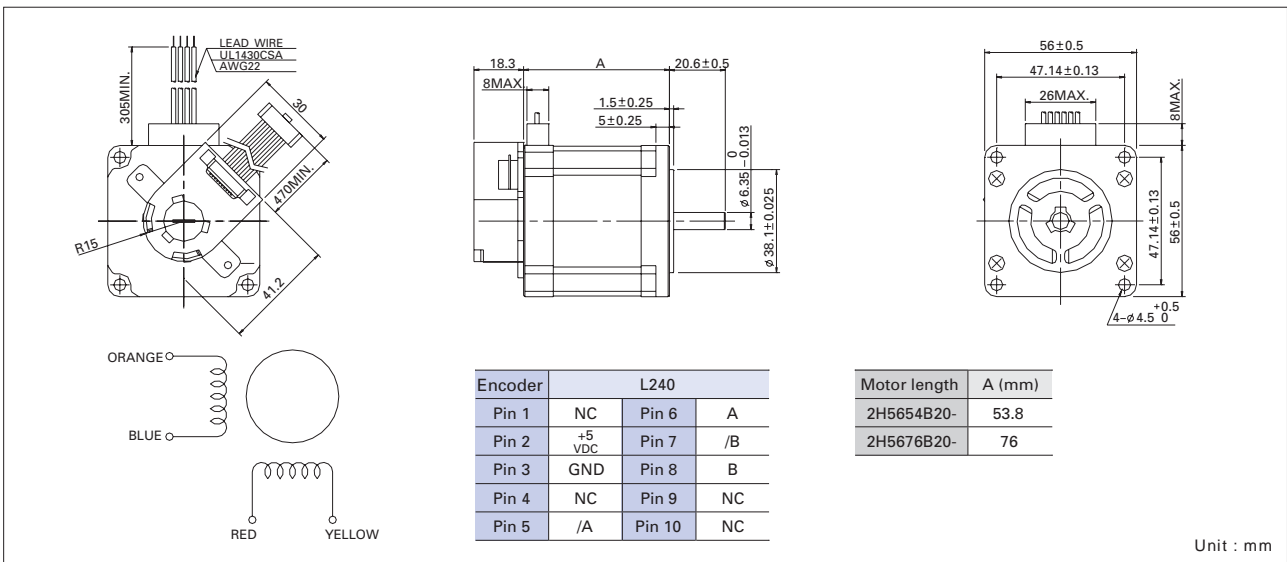

DIAGRAM B5



Dimensions and Connection Diagram

DIAGRAM C1 - MOTOR 2H6086U20

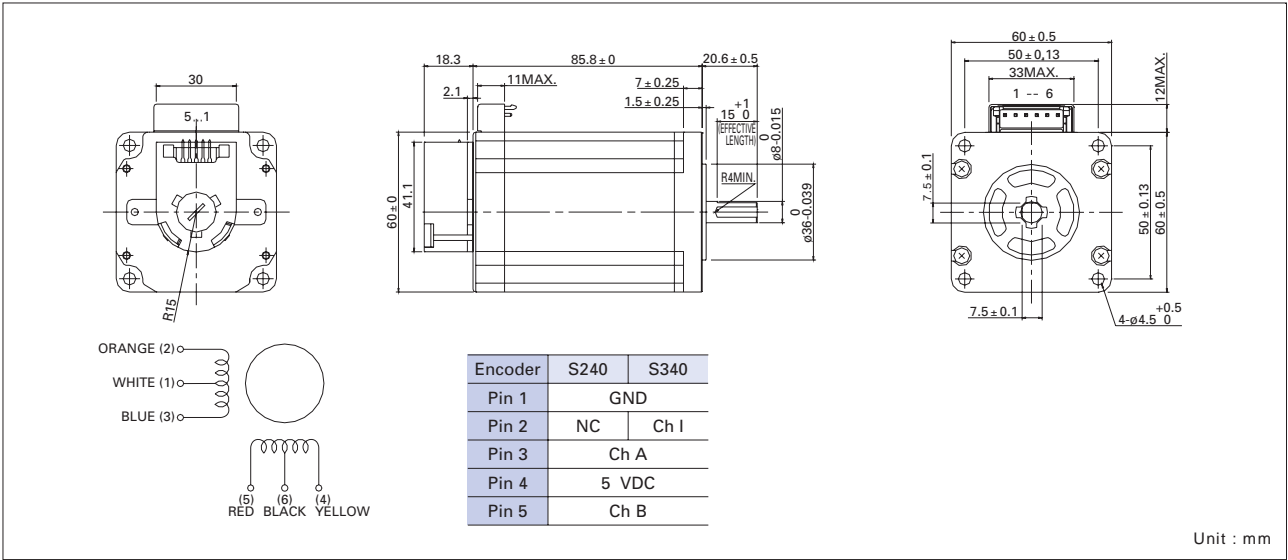

DIAGRAM C2 - MOTOR 2H6086B40

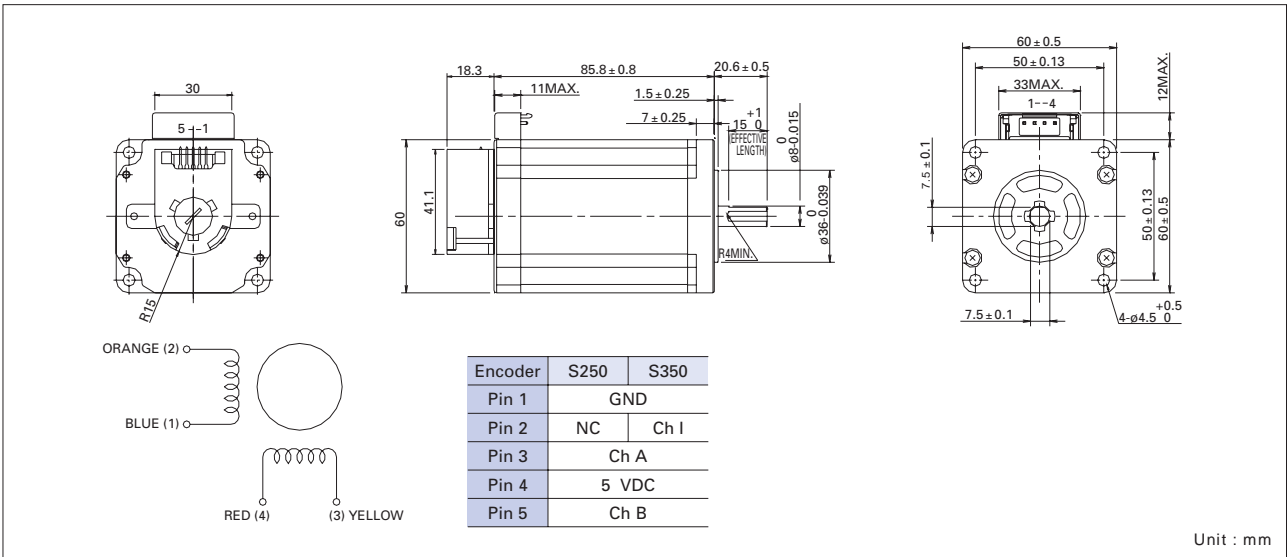
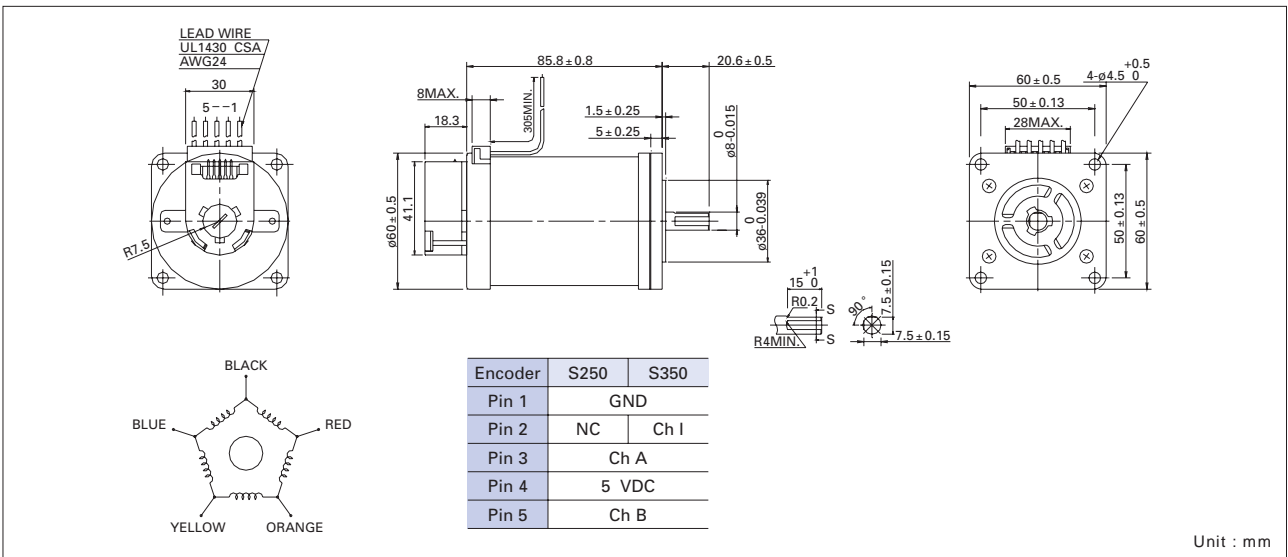
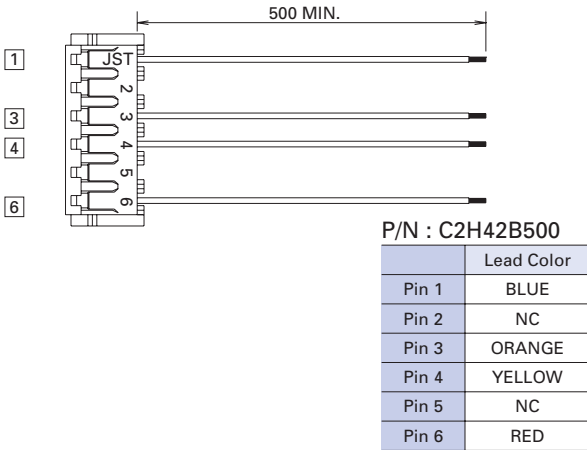

DIAGRAM D1 - MOTOR 5H6086P15



Accessories

Motor flange 42mm cable



Motor flange 60mm cable

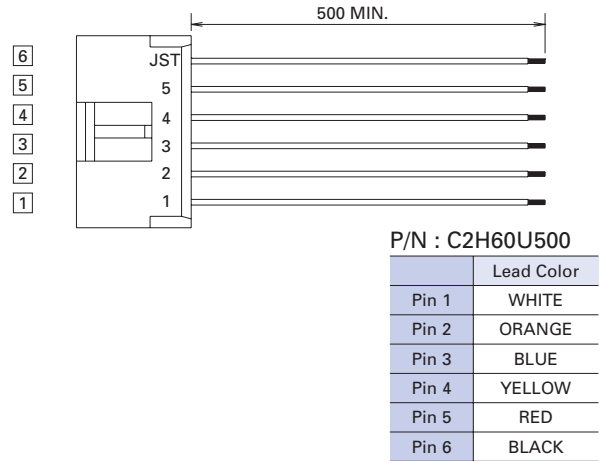
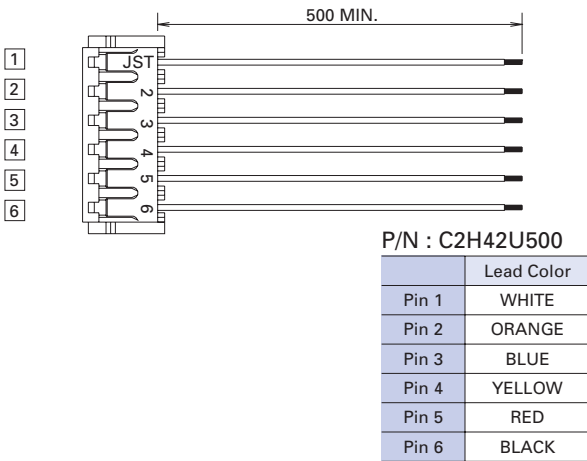
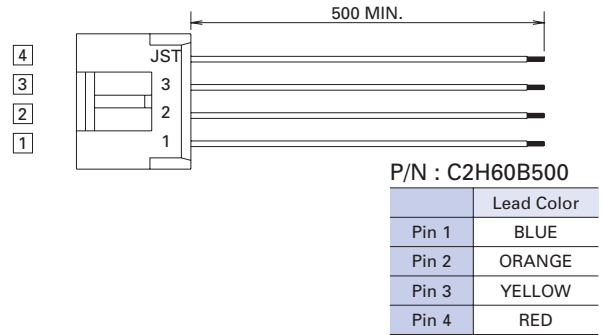

2 Channel Type S encoder cable

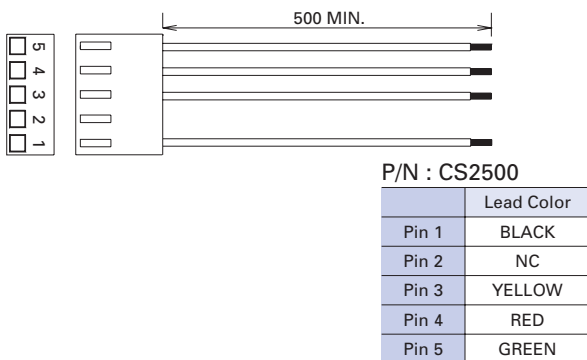

3 Channel Type S encoder cable

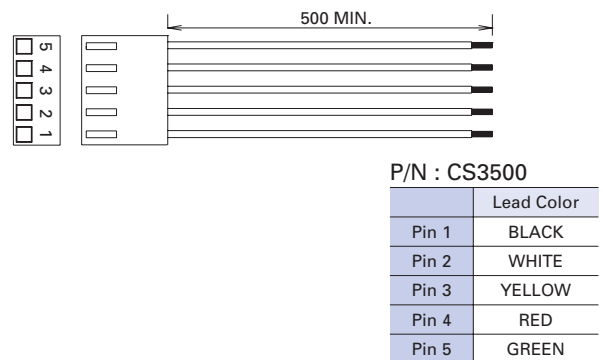

R220 encoder Cable for 2H42 motors

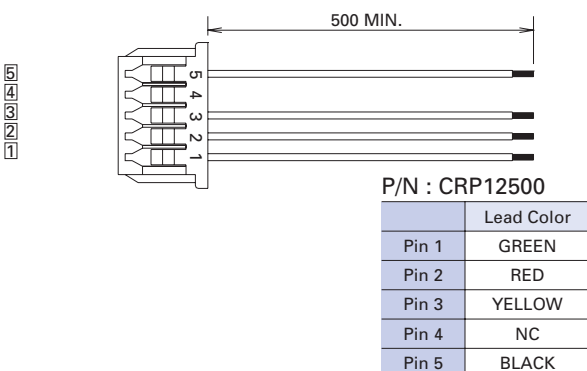

R220 encoder Cable for 2H56 motors

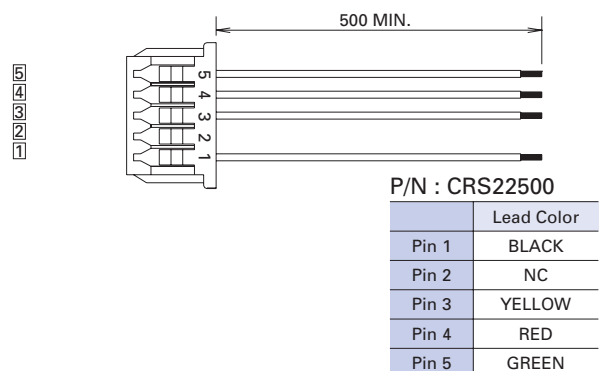

Precautions For Adoption



Failure to follow the precautions on theright may cause moderate injury and property damage, or in some circumstances, could lead to a serious accident. Always follow all listed precautions.

Cautions

- Read the accompanying Instruction Manual carefully prior to using the product.
- If applying to medical devices and other equipment affecting people's lives, please contact us beforehand and take appropriate safety measures.
- If applying to equipment that can have significant effects on society and the general public, please contact us beforehand.
- Do not use this product in an environment where vibration is present, such as in a moving vehicle or shipping vessel.
- Do not perform any retrofitting, re-engineering, or modification to this equipment.
- The amplifiers presented in this catalog are meant to be used for general industrial applications. If using for special applications related to aviation and space, nuclear power, electric power, submarine repeaters, etc., please contact us beforehand.

* For any question or inquiry regarding the above, contact our Sales Department.

SANYO DENKI EUROPE SA.

P.A. PARIS NORD II 48 Allée des Erables-VILLEPINTE BP.50286 F-95958 ROISSY CDG CEDEX France

<http://www.sanyodenki.eu>

Phone:+33 1 48 63 26 61

*Remarks:Specifications Are Subject To Change Without Notice.

06.12.N