

San Ace 60 CR type

Counter Rotating Fans 60mm

Features

Large air flow and high static pressure

- Mass : reduced by approx. 33%
- Maximum airflow : about the same as before
- Maximum static pressure : increased by approx. 9% compared with our conventional product*.

Energy-Saving Design

- Power consumption : reduced by approx. 29% with airflow performance that is identical to our conventional product*.

* Our conventional product is the DC cooling fan :
60 mm square × 76 mm thick fan "San Ace 60" (9CR0612S001)



60mm square × 51mm thick

Specifications

Model No.	Rated Voltage (V)	Operating Voltage Range (V)	PWM duty cycle* (%)	Rated Current (A)	Rated Input (W)	Rated Speed (min ⁻¹)		Air Flow		Static Pressure		SPL (dB[A])	Operating Temperature Range (°C)	Life Expectancy (h)
						Inlet	Outlet	(m ³ /min)	(CFM)	(Pa)	(inchH ₂ O)			
9CR0612P5G03	12	10.8 to 13.2	100	2.7	32.4	11,500	9,000	2.03	71.7	600	2.41	68	-10 to +70	40,000
			0	0.22	2.64	3,000	2,300	0.48	16.9	40	0.16	34		
9CR0612P5H03			100	2.0	24.0	10,500	8,200	1.85	65.4	500	2.01	65		
			0	0.22	2.64	3,000	2,300	0.48	16.9	40	0.16	34		

※PWM Frequency : 25kHz

Common Specifications

- Material Frame: Plastics (Flammability: UL94V-0) , Impeller: Plastics (Flammability: UL94V-1)
- Life Expectancy Varies for each model
(L10: Survival rate: 90% at 60°C, rated voltage, and continuously run in a free air state)
- Motor Protection System Current blocking function and Reverse polarity protection
- Dielectric Strength 50/60 Hz, 500VAC, 1 minute (between lead conductor and frame)
- Sound Pressure Level (SPL) Expressed as the value at 1m from air inlet side
- Operating Temperature Range Varies for each model (Non-condensing)
- Lead Wire Inlet ⊕red ⊖black Sensor: yellow Control: brown
Outlet ⊕orange ⊖gray Sensor: purple Control: white
- Mass 180g

60mm

San Ace 60 CR type

Air Flow and Static Pressure Characteristics

• PWM Duty Cycle

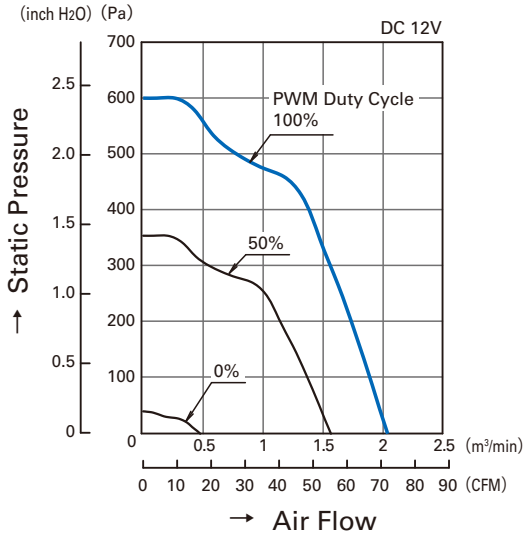

9CR0612P5G03

• Operating Voltage Range

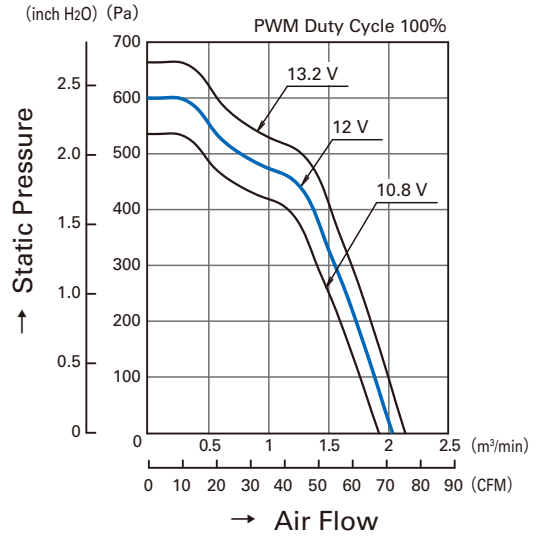

9CR0612P5G03

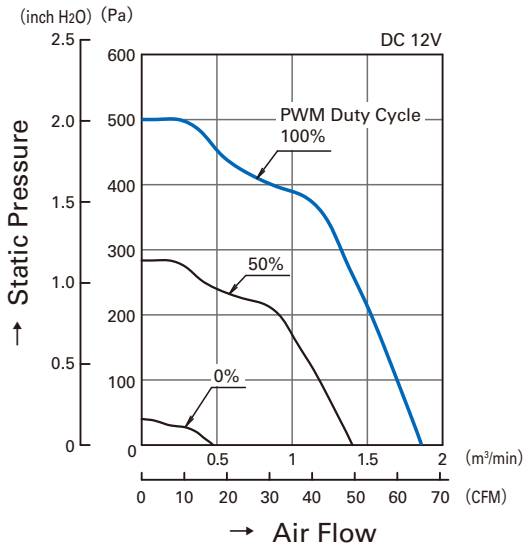

9CR0612P5H03

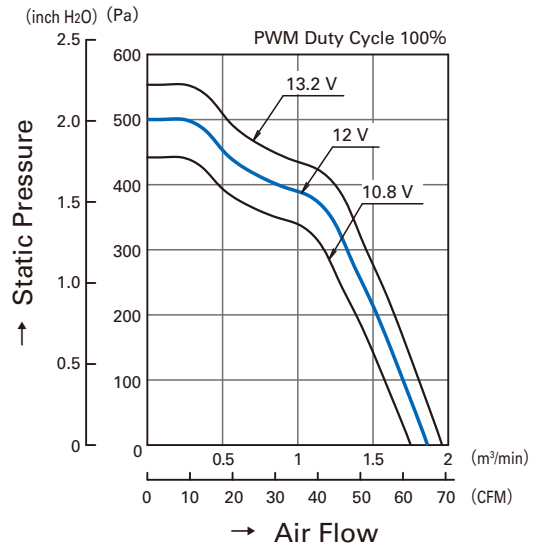

9CR0612P5H03

PWM Duty - Speed Characteristics Example

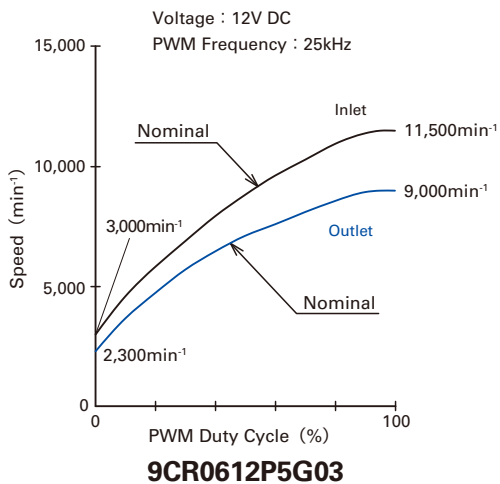

9CR0612P5G03

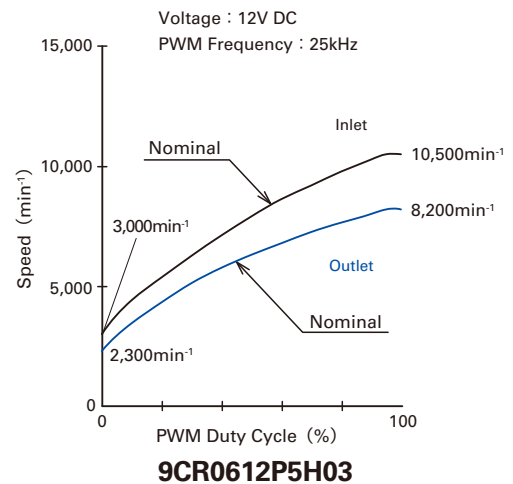

9CR0612P5H03

PWM Input Signal Example

Input Signal Wave Form

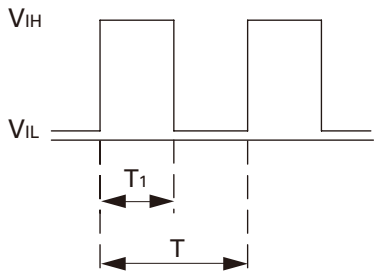

$V_{IH}=4.75V$ to $5.25V$

$V_{IL}=0V$ to $0.4V$

PWM Duty Cycle (%) = $\frac{T_1}{T} \times 100$

PWM Frequency 25 (kHz) = $\frac{1}{T}$

Source Current (I_{source}) : 2mA Max. at control voltage 0V

Sink Current (I_{sink}) : 2mA Max. at control voltage 5.25V

Control Terminal Voltage : 5.25V Max. (Open Circuit)

When the control lead wire is no connecting, the speed is the same speed as at 100% of PWM cycle.

This fan speed should be controlled by PWM input signal of either TTL input or open collector, drain input.

Connection Schematic

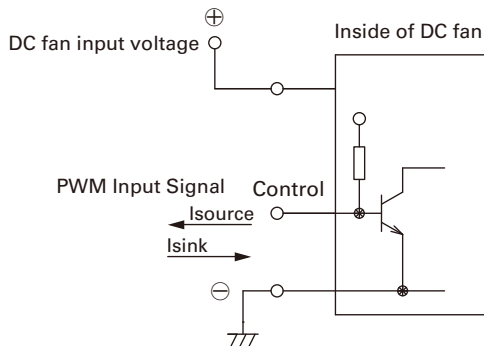

Specifications for Pulse Sensors

Output circuit : Open collector

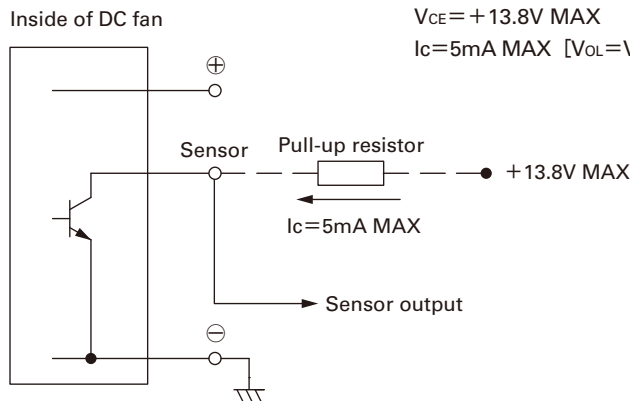

$V_{CE}=+13.8V$ MAX

$I_c=5mA$ MAX [$V_{OL}=V_{CE(SAT)}=0.6V$ MAX]

Output waveform (Need pull-up resistor)

In case of steady running

(One revolution)

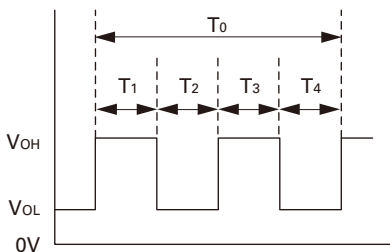

$T_{1\sim 4} \cong (1/4) T_0$

$T_{1\sim 4} \cong (1/4) T_0 = 60/4N$ (sec)

$N = \text{Fan speed (min}^{-1}\text{)}$

Dimensions (unit : mm)

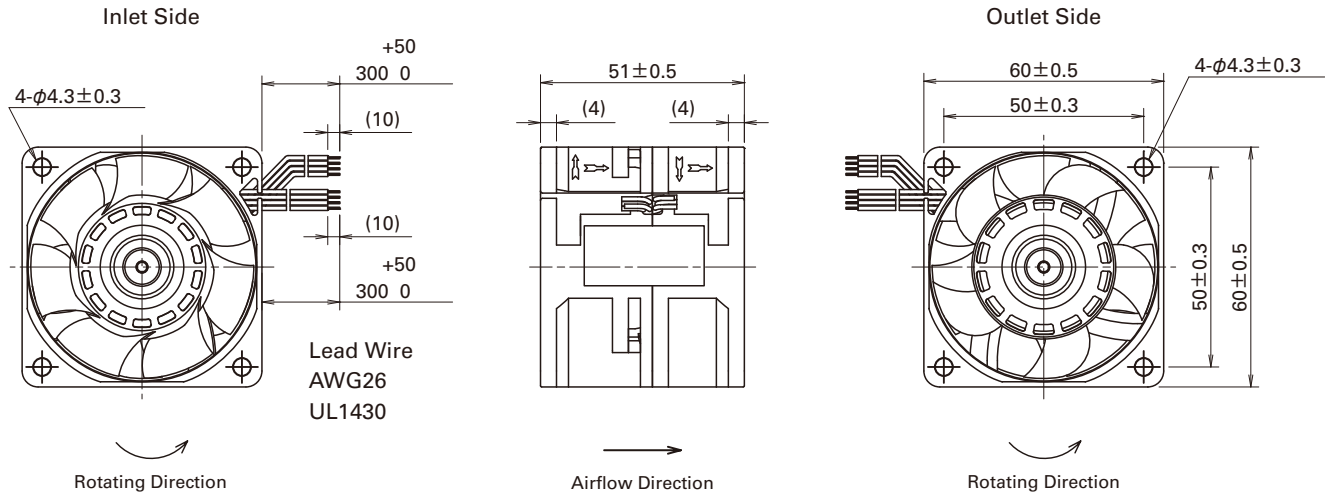

Reference dimension of mounting holes and vent opening (unit : mm)

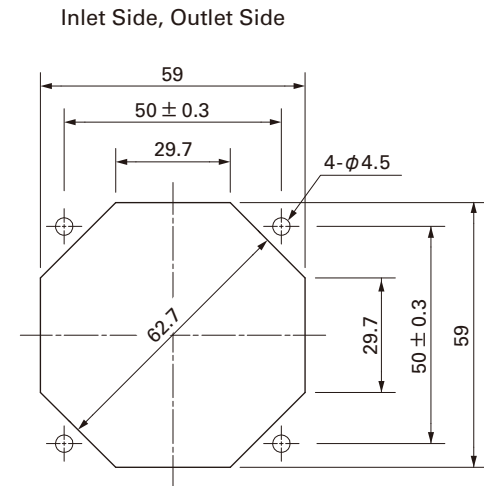

Notice

- The products shown in the catalog are subject to Japanese Export Control Law. Diversion contrary to the law of exporting country is prohibited.
- To protect against electrolytic corrosion that may occur in locations with strong electromagnetic noise, we provide fans that are unaffected by electrolytic corrosion.