

SANMOTION R

AC SERVO SYSTEMS

ADVANCED MODEL

AC Servo amplifier

Applications : chip mounter, semiconductor equipment, and machine tool.



50% Shorter Position Settling Time[※]

The vibrations of the low rigidity machine stand resonance is minimized, and shortens positioning settling time. The amplifier is suitable for chip mounters and equipment needs high speed positioning.

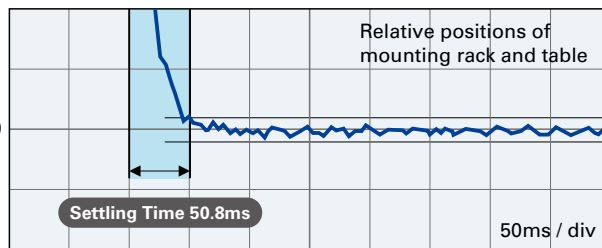

Our conventional product

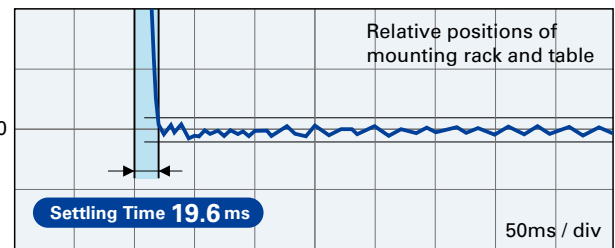

ADVANCED MODEL (Model following vibration suppression control)

15% Increased Torque of High Rotation Speed[※]

By increasing torque under high-speed rotation, motor size is reduced. This contributes to downsizing the equipments.

• The increasing rate changes by the motor.

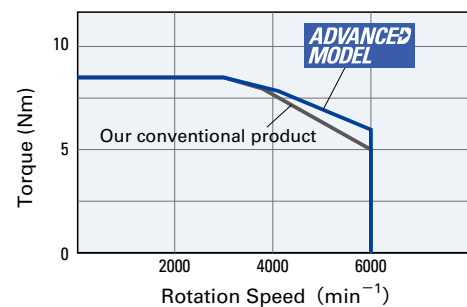

Safety Model newly added to lineup

Since this new model safely shutdown motor torque, safety system is more easily installed on the equipments. This safety function is defined in the “IEC61800-5-2: Safe Torque Off” and “IEC60204-1 : Stop Category 0”. In addition, this model has aquired “IEC61508, SIL2 / IEC62061,SILCL2” and “ISO13849-1 : Cat.3,PL=d”.



※Compared with our conventional product “SANMOTION R”.

Explanation of Model Number

ex. RS2Series Servo Amplifier models, Input voltage AC200V, Amplifier capacity 15A,
With built-in regenerative resistance/ with DB resistance, With safety function.

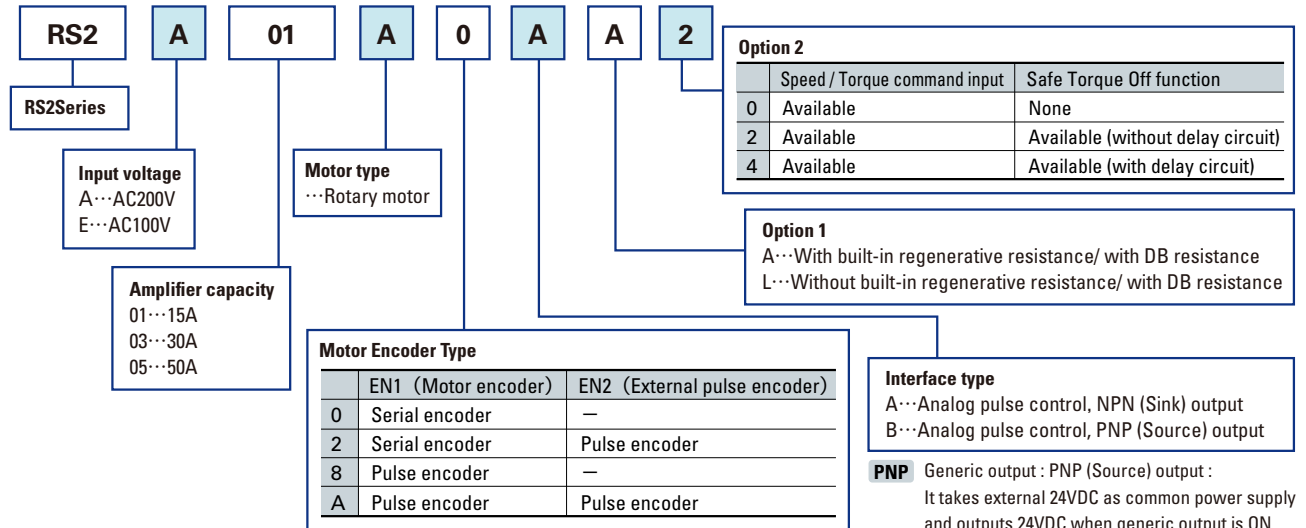

General specifications

Control function	Position control/Speed control/Torque control (Parameter changeover)		Note1) Power source voltage should be within the specified range AC200V Power input type: Specified power supply range = AC170V to AC253V AC100V Power input type: Specified power supply range = AC85V to AC127V Note2) AC100V single-phase input type corresponds only to, RS2□01/RS2□03
Control system	IGBT : PWM control Sinusoidal drive		
Main Circuit Power <small>Note1)</small>	Three-phase : AC200 to 230V+10, -15%, 50/60Hz±3Hz Single-phase : AC200 to 230V+10, -15%, 50/60Hz±3Hz Single-phase : AC100 to 115V+10, -15%, 50/60Hz±3Hz <small>Note2)</small>		
Controlling circuit <small>Note1)</small>	Single-phase : AC200/230V+10, -15%, 50/60Hz±3Hz Single-phase : AC100 to 115V+10, -15%, 50/60Hz±3Hz <small>Note2)</small>		
Environment	Ambient temperature	0 to 55°C	
	Storage temperature	-20 to +65°C	
	Operation/Storage humidity	Below 90%RH (no condensation)	
	Elevation	Below 2000m sea level	
	Vibration	0.5G Frequency range 10 to 55Hz tested for 2H in each direction X.Y.Z	
Shock	2G		
Structure	Built-in tray type power supply		

Performance

Speed control range	1 : 5000 (Internal speed command)
Frequency characteristics	1200Hz (In case of high frequency sampling mode)

Built-in functions

Protection functions	Over current, Current detection error, Overload, Regeneration error, Amplifier overheating, External overheating, Over voltage, Main circuit power low voltage, Main circuit power supply open phase, Control power supply low voltage, Encoder error, Over speed, Speed control error, Speed feedback error, Excessive position, Position command pulse error, Built-in memory error, Parameter error		
LED display	Status display, Monitor display, Alarm display, Parameter setting, Adjustment mode		
Dynamic brake circuit	Built-in	Regeneration process circuit	Built-in
Monitor	Speed monitor (VMON)	2.0V±10% (at 1000min ⁻¹)	
	Current monitor (IMO)	2.0V±10% (at 100%)	

Safety standards

Servo amplifier type	Safety standards		
All models	UL ratings	UL508C	
	EN standards	Low-voltage directive	· EN61800-5-1
		EMC directive	· EN55011 G1 ClassA · EN61000-6-2 · EN61800-3
Model with safety function	Function safety standards	· IEC61508, SIL2 · IEC62061, SILCL2 · ISO13849-1, Cat. 3, PL=d · EN954-1, Cat. 3	

AC Servo amplifier **SANMOTION R ADVANCED MODEL** + AC Servo motor **SANMOTION R**

input voltage **AC200V**

Power supply range AC170V to AC253V

Item	Symbol	Unit	Specification		
Servo Amplifier Model			RS2A01 * *		
Capacity		A	15		
Servo motor model			R2AA04003F	R2AA04005F	R2AA04010F
Flange Size		mm	40	40	40
Rated Output	★ P _R	kW	0.03	0.05	0.1
Rated Speed	★ N _R	min ⁻¹	3000	3000	3000
Maximum Speed	★ N _{max}	min ⁻¹	6000	6000	6000
Rated Torque	★ T _R	N·m	0.098	0.159	0.318
Continuous Torque at Stall	★ T _S	N·m	0.108	0.167	0.318
Peak Torque at Stall	★ T _P	N·m	0.37	0.59	1.18
Rated Armature Current	★ I _R	Arms	0.51	0.67	0.81
Armature Current at Stall	★ I _S	Arms	0.56	0.69	0.81
Peak Armature Current at Stall	★ I _P	Arms	2.15	2.8	3.3
Torque Constant	K _T	N·m/Arms	0.201	0.246	0.424
Voltage Constant Per Phase	K _{Eφ}	mV/min ⁻¹	7.0	8.6	14.8
Phase Resistance	R _φ	Ω	12	9	9.3
Rated Power Rate	★ Q _R	kW/s	3.9	6.7	16
Moment of inertia <small>Note1)</small>	J _M	kg·m ² (GD ² /4)×10 ⁻⁴	0.028	0.0409	0.066
Mass <small>Note1)</small>	WE	kg	0.23	0.27	0.39
Brake Mass	W	kg	0.23	0.23	0.23

Note 1) Contains battery backup method absolute encoder.

Note 2) It is the constant for the installation on the t6x250mm size aluminum board for the heat radiation.

Note 3) Items with★and velocity – torque characteristics indicate values after temperature rise saturation. The others indicate values at 20°C.

Note 4) Each value indicates TYP.

Speed-Torque Characteristics

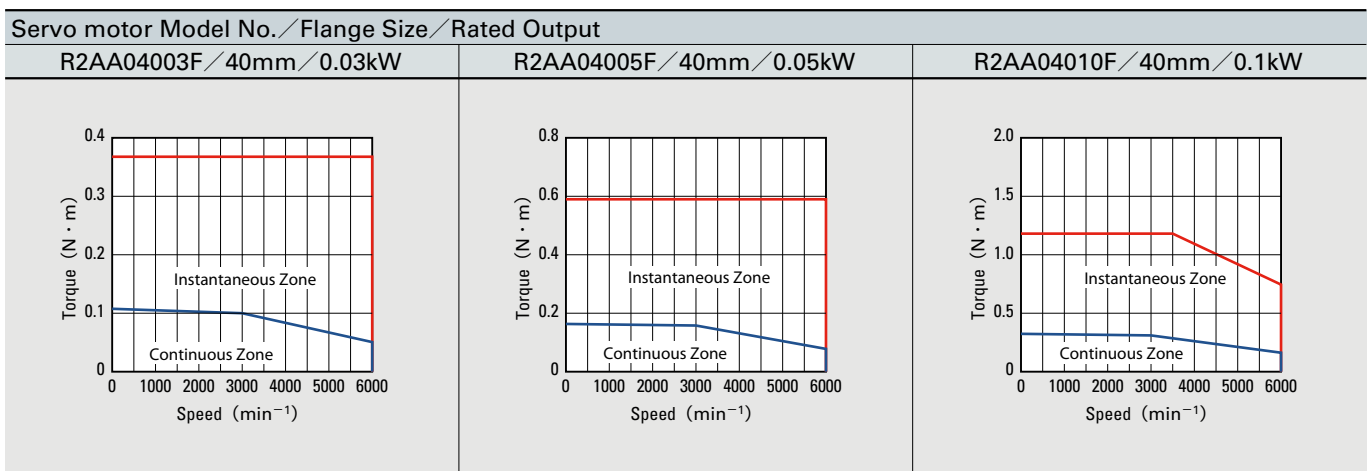

It is value when the input power supply is AC200V three-phase circuit.

The area decreases momentarily when the power supply voltage is less than 200V.

Please contact us when the servo amplifier power supply is less than AC200V.

AC Servo amplifier **SANMOTION R ADVANCED MODEL** + AC Servo motor **SANMOTION R**

input voltage **AC200V**

Power supply range AC170V to AC253V

Item	Symbol	Unit	Specification			
Servo Amplifier Model			RS2A01 * *			RS2A03 * *
Capacity		A	15			30
Servo motor model			R2AA06010F	R2AA06020F	R2AA08020F	R2AA06040F
Flange Size		mm	60	60	80	60
Rated Output	★ P _R	kW	0.1	0.2	0.2	0.4
Rated Speed	★ N _R	min ⁻¹	3000	3000	3000	3000
Maximum Speed	★ N _{max}	min ⁻¹	6000	6000	6000	6000
Rated Torque	★ T _R	N·m	0.318	0.637	0.637	1.27
Continuous Torque at Stall	★ T _S	N·m	0.353	0.686	0.686	1.37
Peak Torque at Stall	★ T _P	N·m	1.13	2.2	2.2	4.8
Rated Armature Current	★ I _R	Arms	0.86	1.5	1.5	2.8
Armature Current at Stall	★ I _S	Arms	0.86	1.6	1.5	2.8
Peak Armature Current at Stall	★ I _P	Arms	3.5	5.6	4.8	10.8
Torque Constant	K _T	N·m/Arms	0.375	0.476	0.516	0.524
Voltage Constant Per Phase	K _{Eφ}	mV/min ⁻¹	13.1	16.6	18.0	18.3
Phase Resistance	R _φ	Ω	4.8	2.7	2.3	1.36
Rated Power Rate	★ Q _R	kW/s	8.6	19	8	39
Moment of inertia <small>Note1)</small>	J _M	kg·m ² (GD ² /4)×10 ⁻⁴	0.120	0.222	0.523	0.415
Mass <small>Note1)</small>	WE	kg	0.59	0.84	1.2	1.3
Brake Mass	W	kg	0.3	0.35	0.85	0.35

Note 1) Contains battery backup method absolute encoder.

Note 2) It is the constant for the installation on the t6x250mm size aluminum board for the heat radiation.

Note 3) Items with★and velocity – torque characteristics indicate values after temperature rise saturation. The others indicate values at 20°C.

Note 4) Each value indicates TYP.

Speed-Torque Characteristics

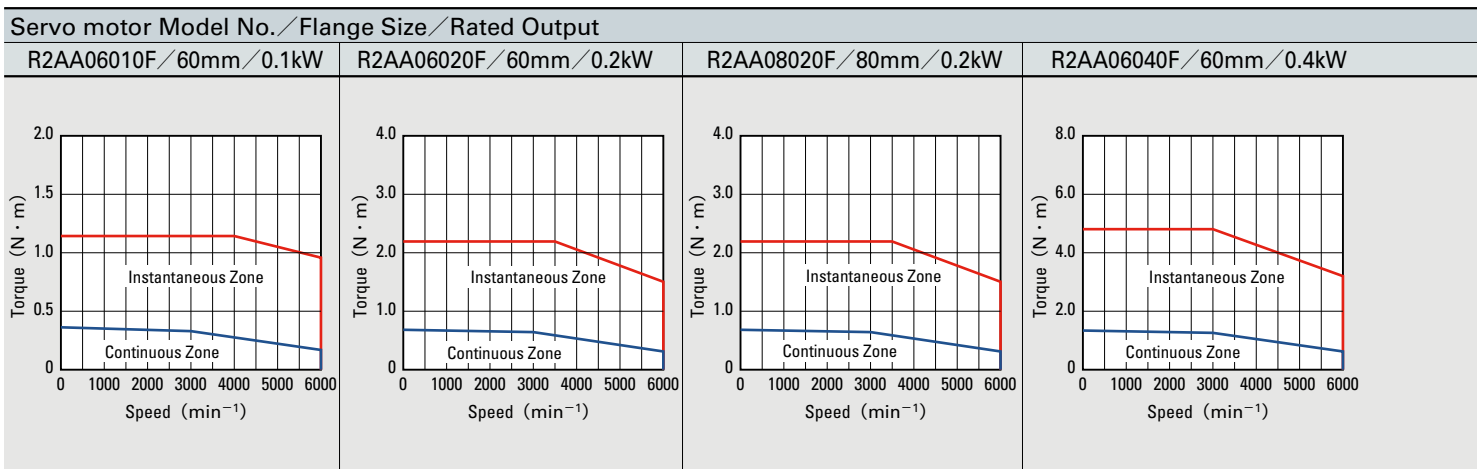

It is value when the input power supply is AC200V three-phase circuit.

The area decreases momentarily when the power supply voltage is less than 200V.

Please contact us when the servo amplifier power supply is less than AC200V.

				Unit	Symbol	Item
RS2A03 * *		RS2A05 * *				Servo Amplifier Model
30		50		A		Capacity
R2AA08040F	R2AA08075F	R2AA13050D	R2AA13120D			Servo motor model
80	80	130	130	mm		Flange Size
0.4	0.75	0.5	1.2	kW	P_R	★ Rated Output
3000	3000	2000	2000	min^{-1}	N_R	★ Rated Speed
6000	6000	5000	5000	min^{-1}	N_{max}	★ Maximum Speed
1.27	2.39	2.6	5.7	$\text{N} \cdot \text{m}$	T_R	★ Rated Torque
1.37	2.55	2.6	6.0	$\text{N} \cdot \text{m}$	T_S	★ Continuous Torque at Stall
4.4	8.5	7.0	16.0	$\text{N} \cdot \text{m}$	T_P	★ Peak Torque at Stall
2.6	4.6	5.2	9.1	Arms	I_R	★ Rated Armature Current
2.6	4.6	5.2	9.3	Arms	I_S	★ Armature Current at Stall
8.9	15.5	15.5	25.4	Arms	I_P	★ Peak Armature Current at Stall
0.559	0.559	0.53	0.65	$\text{N} \cdot \text{m}/\text{Arms}$	K_T	Torque Constant
19.5	19.5	18.5	22.7	$\text{mV}/\text{min}^{-1}$	$K_{E\phi}$	Voltage Constant Per Phase
0.93	0.4	0.39	0.23	Ω	R_ϕ	Phase Resistance
16	31	22	54	kW/s	Q_R	★ Rated Power Rate
1.043	1.823	3.1	6.0	$\text{kg} \cdot \text{m}^2(\text{GD}^2/4) \times 10^{-4}$	J_M	Moment of inertia ^{Note1)}
1.6	2.6	5.0	7.0	kg	WE	Mass ^{Note1)}
0.85	0.85	1.0	1.0	kg	W	Brake Mass

Servo motor Model No./Flange Size/Rated Output

R2AA08040F/80mm/0.4kW

R2AA08075F/80mm/0.75kW

R2AA13050D/130mm/0.5kW

R2AA13120D/130mm/1.2kW

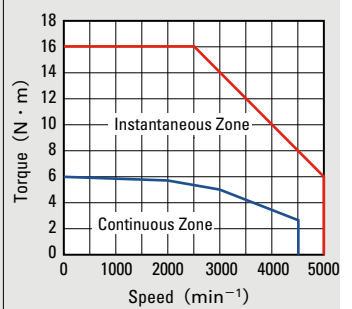
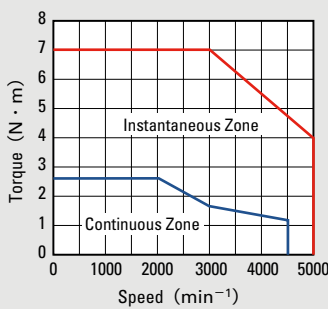
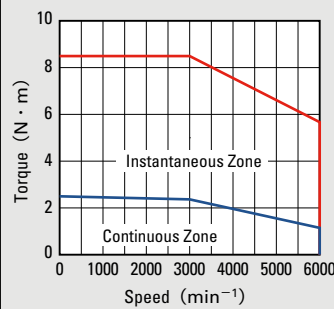
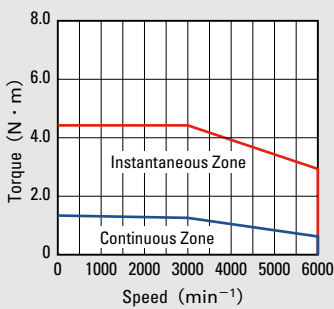



input voltage **AC100V**

Power supply range AC85V to AC127V

Item	Symbol	Unit	Specification			
Servo Amplifier Model			RS2E01 * *			
Capacity		A	15			
Servo motor model			R2EA04003F	R2EA04005F	R2EA04008F	R2EA06010F
Flange Size		mm	40	40	40	60
Rated Output	★ P _R	kW	0.03	0.05	0.08	0.1
Rated Speed	★ N _R	min ⁻¹	3000	3000	3000	3000
Maximum Speed	★ N _{max}	min ⁻¹	6000	6000	6000	6000
Rated Torque	★ T _R	N·m	0.098	0.159	0.255	0.318
Continuous Torque at Stall	★ T _S	N·m	0.108	0.167	0.255	0.318
Peak Torque at Stall	★ T _P	N·m	0.37	0.59	0.86	1.0
Rated Armature Current	★ I _R	Arms	0.94	1.2	1.3	1.7
Armature Current at Stall	★ I _S	Arms	1.0	1.3	1.3	1.7
Peak Armature Current at Stall	★ I _P	Arms	3.7	4.9	4.5	5.6
Torque Constant	K _T	N·m/Arms	0.116	0.142	0.22	0.206
Voltage Constant Per Phase	K _{Eφ}	mV/min ⁻¹	4.04	4.97	7.7	7.2
Phase Resistance	R _φ	Ω	4.0	3.0	2.9	1.5
Rated Power Rate	★ Q _R	kW/s	3.9	6.7	10	8.6
Moment of inertia ^{Note1)}	J _M	kg·m ² (GD ² /4)×10 ⁻⁴	0.028	0.0409	0.066	0.120
Mass ^{Note1)}	WE	kg	0.23	0.27	0.39	0.59
Brake Mass	W	kg	0.23	0.23	0.23	0.30

Note 1) Contains battery backup method absolute encoder.

Note 2) It is the constant for the installation on the t6x250mm size aluminum board for the heat radiation.

Note 3) Items with★and velocity – torque characteristics indicate values after temperature rise saturation. The others indicate values at 20°C.

Note 4) Each value indicates TYP.

Speed-Torque Characteristics

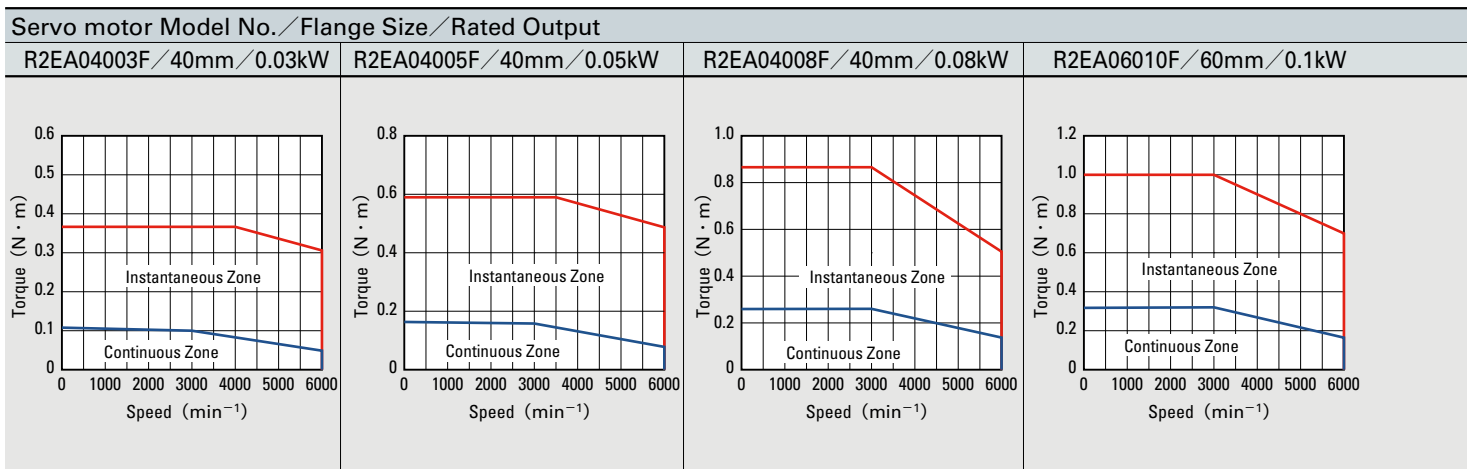

It is value when the input power supply is AC100V.

The area decreases momentarily when the power supply voltage is less than 100V.

External Wiring Diagram

RS2E03**
30
R2EA06020F
60
0.2
3000
6000
0.637
0.686
2.2
3.1
3.2
11.9
0.224
7.82
0.6
19
0.222
0.84
0.35

R2EA06020F / 60mm / 0.2kW

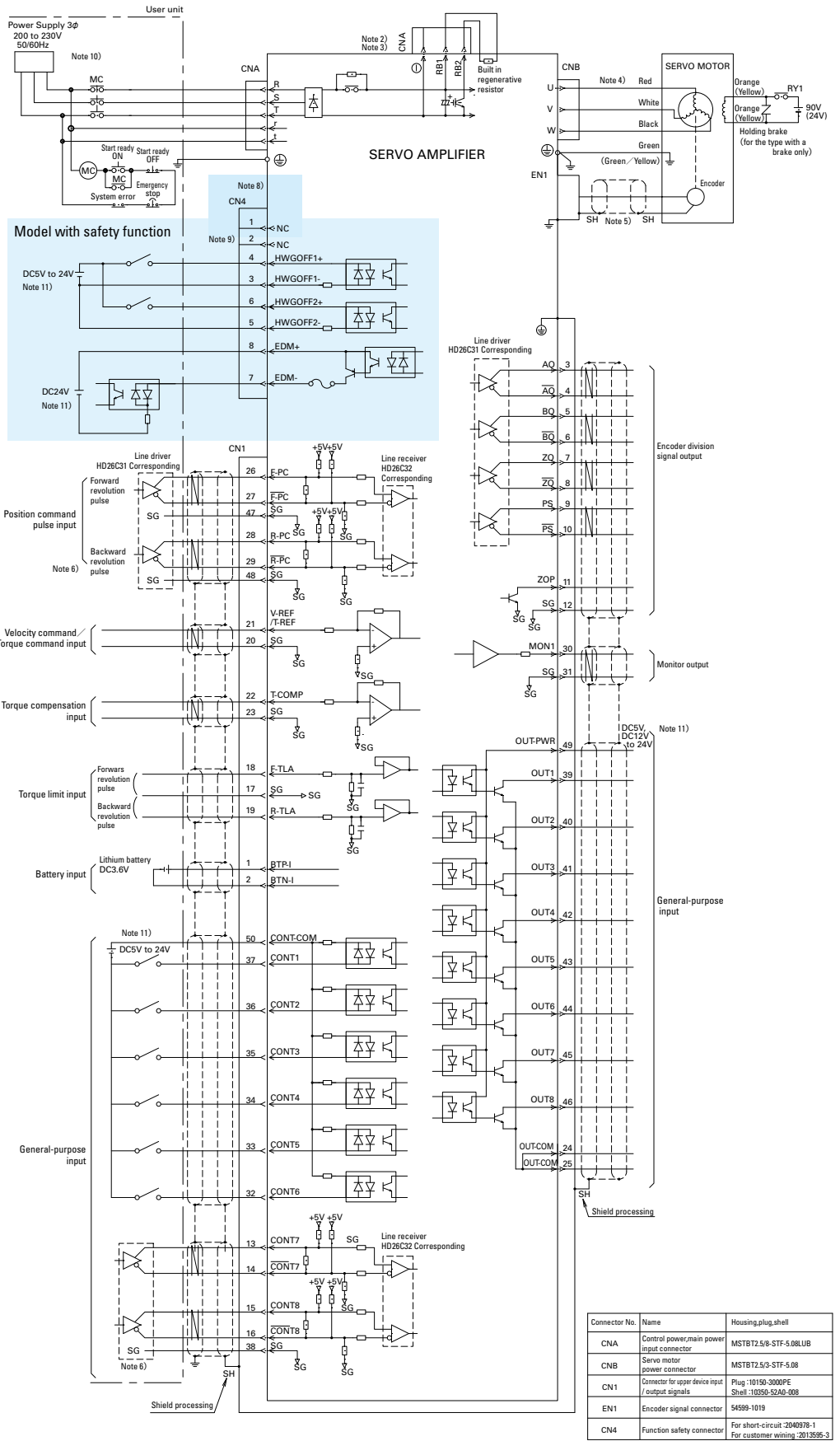
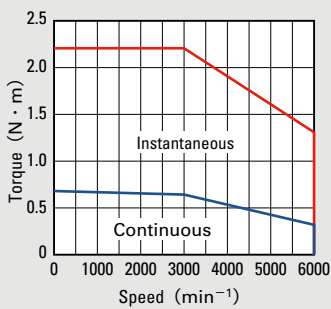

- Note 1) For the parts marked , use a twisted pair shielded cable.
- Note 2) Connect regenerative resistor between RB1 and RB2 terminals. when using external regenerative resistor, connect it between RB1 and RB2 terminals after removing the wiring of built-in regenerative resistor.
- Note 3) ⊖ terminal is for maintenance (high-voltage circuit). So, do not wire this terminal.
- Note 4) Motor connection differs to the motor specifications. The indications of red, white, black, green and orange apply when the motor power and brake lines are the lead type. when they are the cannon plug type, connect them according to the motor specification.
- Note 5) For how to wire the encoder connector, refer to the encoder wiring diagram.
- Note 6) Please be sure to connect SG (signal ground) between equipment with servo amplifier when you use a difference input signal.
- Note 7) The R, S, T, r, t, ⊖, RB1, RB2, U, V, and W terminals are high-voltage circuits and the others are low-voltage circuits. For the wiring-related reason, allow sufficient distance between high- and low-voltage circuits.
- Note 8) CN4 is a connector for safety function signals. To turn the servo motor power ON, a safety device must be connected and the wiring to activate the safety function must be done. When not using the safety function, use the connector (P.N : AL-00718251-01) of an option inserted into the CN4.
- Note 9) Nothing should connect with CN4-1 and 2pin.
- Note 10) It is recommended to use a ground fault interrupter conforming to the UL/IEC and EN standards. Do not wire the S phase for a single-phase power amplifier.
- Note 11) Power should be supplies by the user

Encoder Wiring Diagram

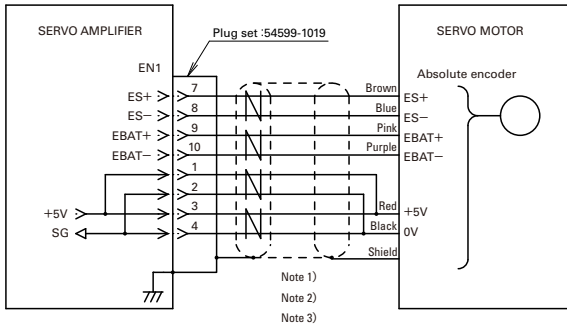

Serial Encoder

- Battery backup type absolute encoder [PA035C]
- Absolute encoder for incremental system [PA035S]
- Batteryless absolute encoder [RA035C]

Note 1) Use a twisted-pair shielded cable.
 Note 2) Encoder power connections depend on encoder cable length. See the following

Encoder cable length	+5V DC Wiring	0V DC Wiring	Wire gauge
10m MAX.	Connect pin 1 (Do not connect pin 3)	Connect pin 2 (Do not connect pin 4)	AWG24
25m MAX.	Connect pins 1,3	Connect pins 2,4	AWG24

Note 3) When the Absolute encoder for incremental system or absolute encoder without battery is used, battery lines (EBAT+, EBAT-) are not required.

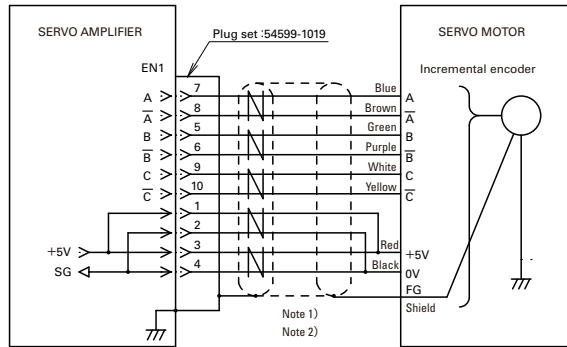

Pulse Encoder

- Wire-saving incremental encoder [PP031T]

Note 1) Use a twisted-pair shielded cable.
 Note 2) Encoder power connections depend on encoder cable length. See the following

Encoder cable length	+5V DC Wiring	0V DC Wiring	Wire gauge
5m MAX.	Connect pin 1 (Do not connect pin 3)	Connect pin 2 (Do not connect pin 4)	AWG24
10m MAX.	Connect pins 1,3	Connect pins 2,4	AWG24
20m MAX.	Connect pins 1,3	Connect pins 2,4	AWG22

Dimensions (Unit : mm)

RS2*01A* (15A)

Mass : 0.75kg

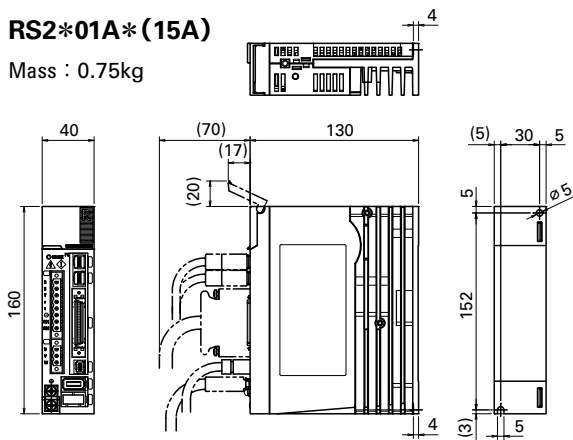

RS2*03A* (30A)

Mass : 0.9kg

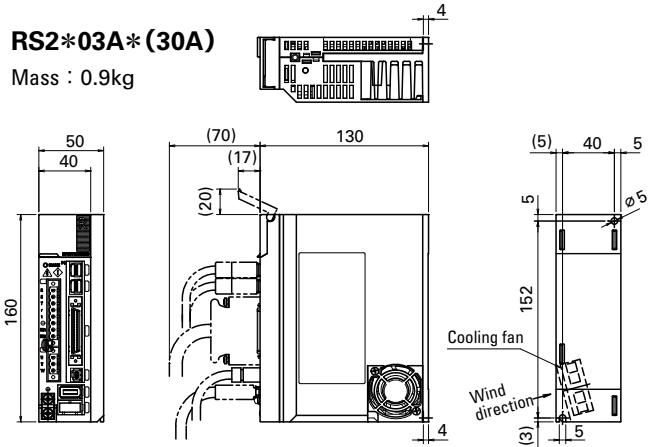

RS2*05A* (50A)

Mass : 1.65kg

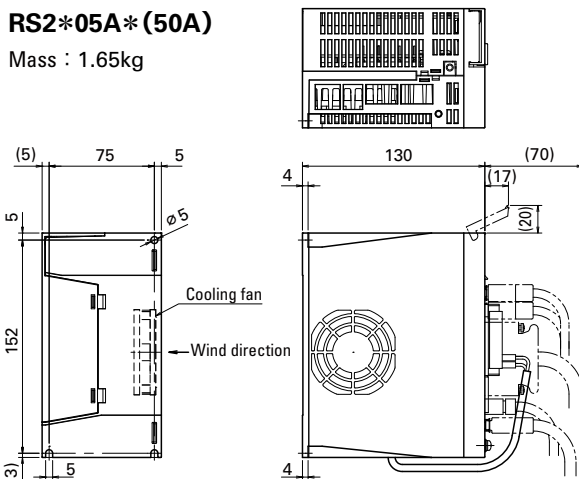

Notice

●The products shown in the catalog are subject to Japanese Export Control Law. Diversion contrary to the law of exporting country is prohibited.